



jGun® SINGLE SPEED Pneumatic Torque Tool

The jGun SINGLE SPEED is the simple choice for air-powered industrial bolting. With industry-leading power-to-weight and a breakout force that overcomes corroded and damaged nuts, this tool takes over where impact guns and breaker bars don't cut it.

POWERFUL BREAKOUT



The jGun SINGLE SPEED provides continuous power with no kickback to break out the nuts that other systems can't tackle. Impact guns have tremendous vibration and noise and have been banned on many job sites. It uses precision gearing and a simple reaction fixture to give you maximum power without the noise and vibration.

REPEATABLE TORQUE



For maximum joint integrity, all of the bolts on a connection need to have an even and accurate load. The jGun SINGLE SPEED provides adjustable and repeatable torque to ensure that the bolted joint is assembled right the first time and keeps the torque over time.

ERGONOMIC DESIGN



The jGun SINGLE SPEED is built using aerospace materials for lightweight design with maximum durability. The comfort grip and available silencer ensure that the tool operator is comfortable, even on all-day jobs.

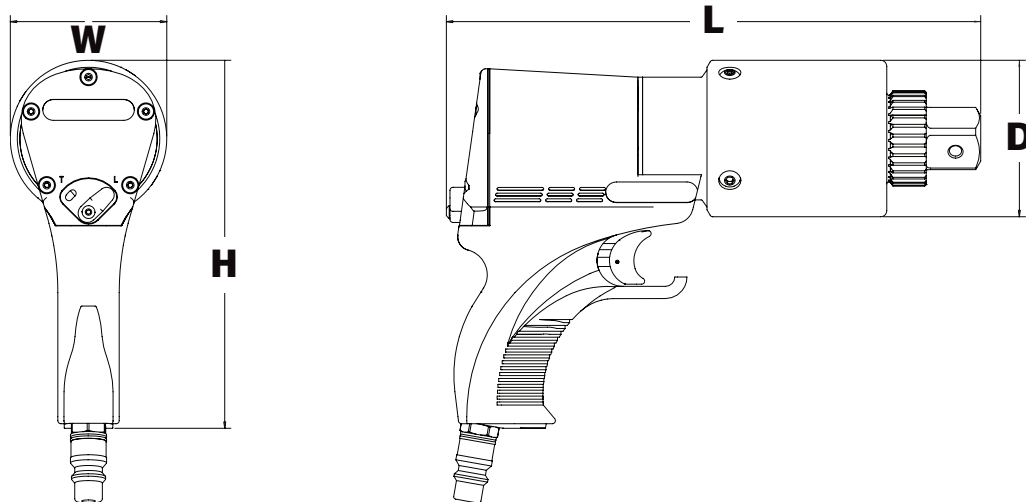

LEGEND: H = HEIGHT W = WIDTH L = LENGTH D = OUTER DIAMETER OF GEARBOX

MODEL NUMBER	H	W	L	D	SQUARE DRIVE	WEIGHT	TORQUE		RPM
IMPERIAL	in.					lbs.	ft-lbs (Min)	ft-lbs (Max)	
J - .25	7.32	2.74	7.03	2.50	3/4	7.20	48	250	65.0
J - .5	7.32	2.74	8.07	2.58	3/4	7.20	129	508	24.0
JGUN-A.7-HS	7.94	3.53	9.93	2.58	3/4	10.40	175	725	26.0
J - 1	7.32	2.74	8.90	2.58	3/4	10.00	301	1231	6.5
J - 2	7.94	3.53	10.46	3.25	1	14.50	521	2190	5.5
J - 3	7.94	3.53	11.11	3.25	1	15.74	852	3104	5.0
J - 5	8.25	4.15	12.68	4.15	1-1/2	20.05	1150	5266	2.5
J - 8	8.46	4.56	13.90	4.56	1-1/2	26.50	1743	7924	1.5

METRIC	mm				in.	kg	Nm (Min)	Nm (Max)	RPM
J - .25	186	70	179	64	3/4	3.27	65	339	65.0
J - .5	186	70	205	66	3/4	3.27	175	688	24.0
JGUN-A.7-HS	202	90	252	66	3/4	4.73	237	982	26.0
J - 1	186	70	226	66	3/4	4.55	408	1668	6.5
J - 2	202	90	266	83	1	6.59	706	2967	5.5
J - 3	202	90	282	83	1	7.15	1154	4206	5.0
J - 5	210	105	322	105	1-1/2	9.11	1558	7136	2.5
J - 8	215	116	353	116	1-1/2	12.05	2362	10737	1.5

The World's Most Trusted Industrial Bolting Systems

HYTORC owns all content, copyrights, trademarks and patents in this document. © 2021 HYTORC. Any unauthorized use or distribution of any material from this document is strictly prohibited.



Headquarters:
333 Route 17 N., Mahwah, NJ 07430
+1-201-512-9500

Email:
info@hytorc.com

Phone:
1-800-FOR-HYTORC

Online:
hytorc.com