



LITHIUM SERIES® Electric Torque Tool

The LITHIUM SERIES is the ultimate solution for portability and convenience on industrial bolting jobs. With the world's first 36-volt industrial battery system, these tools are ready for heavy industrial use. The lightweight design and dual speed capability make this system the go-to choice for industrial maintenance and production environments worldwide.

INDUSTRIAL-GRADE POWER



The LITHIUM SERIES was designed from the ground up using aerospace-grade materials to provide a compact design with industrial durability and power. The metal frame cut from a solid piece of aluminum alloy protects the tool from damage on industrial jobs. The 36-volt battery gives you the power to get through the toughest bolted joints.

DUAL SPEED BOLTING



With a simple switch, the LITHIUM SERIES goes from high speed rundown mode to accurate final torque mode, eliminating the need for multiple systems on a job. The precision machined gearbox provides constant power without the vibration and noise found in impact guns. Adjust the power through the digital readout on the back of the gun to fine-tune the torque output for any job.

DATA RECORDING



Built-in data recording capability allows the user to maintain a log of all completed bolting jobs. For improved quality control and accountability, the information can be saved to a PC or tablet to provide a permanent record of the work performed.

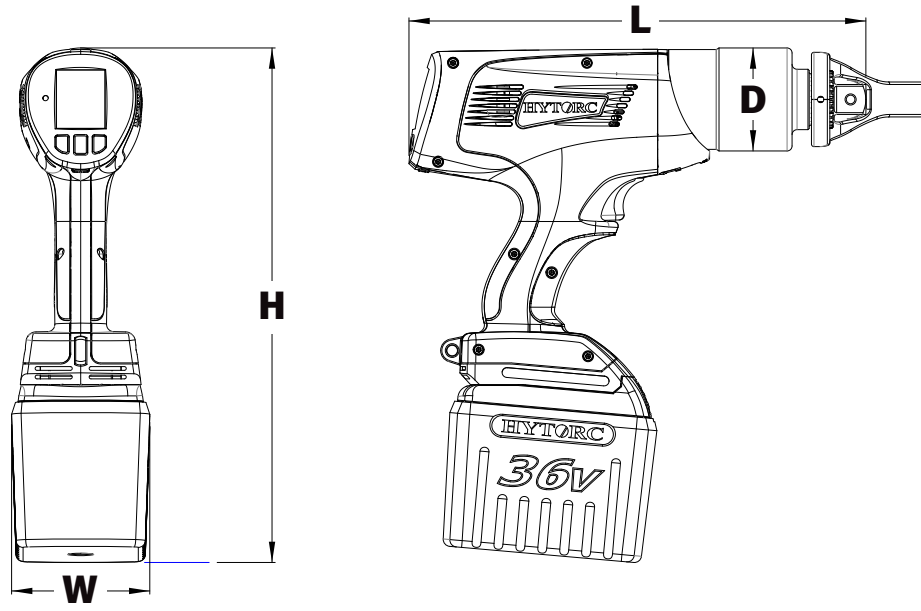

LEGEND: H = HEIGHT W = WIDTH L = LENGTH D = DIAMETER

MODEL NUMBER	H	W	L	D	SQUARE DRIVE	WEIGHT	TORQUE		RPM	
IMPERIAL	in.					lbs.	ft-lbs (Min)	ft-lbs (Max)	High	Low
BTM - 0700	12.85	3.47	11.40	2.58	3/4	10.20	150	700	59.5	5.4
BTM - 1000	12.85	3.47	11.40	2.58	3/4	10.60	200	1,200	39	2.8
BTM - 2000	13.20	3.47	13.00	3.19	1	14.20	325	2,000	17	1.3
BTM - 3000	13.30	3.47	14.11	3.41	1	16.26	500	3,000	11	0.8
METRIC	mm				in.	kg	Nm (Min)	Nm (Max)	High	Low
BTM - 0700	326	88	290	66	3/4	4.64	203	949	59.5	5.4
BTM - 1000	326	88	290	66	3/4	4.82	271	1626	39	2.8
BTM - 2000	335	88	330	81	1	6.45	440	2710	17	1.3
BTM - 3000	338	88	358	87	1	7.39	678	4065	11	0.8

The World's Most Trusted Industrial Bolting Systems

HYTORC owns all content, copyrights, trademarks and patents in this document. © 2021 HYTORC. Any unauthorized use or distribution of any material from this document is strictly prohibited.

HYTORC

Headquarters:
333 Route 17 N., Mahwah, NJ 07430
+1-201-512-9500

Email:
info@hytorc.com

Phone:
1-800-FOR-HYTORC

Online:
hytorc.com