



# XLT/MXT/MXT-SA SERIES

## OPERATIONS MANUAL



**XLT PRODUCT FAMILY:**

HY-1XLT, HY-3XLT, HY-5XLT, HY-8XLT, HY-10XLT,  
HY-20XLT, HY-20XLT, HY-25XLT, HY-50XLT

**MXT PRODUCT FAMILY:**

MXT-.7, MXT-1, MXT-3, MXT-4, MXT-5,  
MXT-10, MXT-15, MXT-20, MXT-35

**MXT-SA PRODUCT FAMILY:**

MXT-.7-SA, MXT-1-SA, MXT-3-SA,  
MXT-5-SA, MXT-10-SA

**EN, EN-ISO, ISO Standards:**

EN ISO 12100-1:2011	EN ISO 4413:2010
EN ISO 12100-2:2011	EN 61310-2:2008
EN ISO 14121-1:2007	EN 61310-3:2008
EN ISO 11148-6:2012	ISO 3744:2011

For a complete EC declaration of conformity or if you require any further assistance please contact your local HYTORC representative or 1-800-FOR-HYTORC (1-800-367-4986) or on the web at [www.HYTORC.com](http://www.HYTORC.com).

## Copyright

© 2018 HYTORC. All rights reserved.

This document or parts thereof may not be reproduced, copied, distributed, stored in a retrieval system, or transmitted in any form or by any means, electronically nor otherwise, without the prior written consent of HYTORC.

Specifications and illustrations are subject to change without prior notice. HYTORC will not accept liability for any alteration or typing error. Details and values given in this manual are average values and have been compiled with care. Details and values are not binding. HYTORC disclaims any liability for damage or detriments suffered as a result of reliance on the information given herein or the use of products, processes or equipment to which this document refers.

For the latest safety and operational guidelines, please schedule a free training with your local HYTORC representative.

# Contents

<b>1</b>	About the document .....	05
	1.1 Purpose of the document	
	1.2 How to work with the document	
	1.3 Languages	
	1.4 Illustrations	
	1.5 Safety symbols in the document	
	1.6 Related documents	
	1.7 Revision history	
	1.8 Contact information	
<b>2</b>	Safety .....	07
	2.1 General safety instructions	
	2.1.1 Personnel	
	2.1.2 Work area	
	2.1.3 Equipment	
	2.2 Additional safety instructions	
	2.2.1 Pump units	
	2.2.2 Electric pump units	
	2.2.3 Hydraulic hoses	
	2.2.4 Reaction arms	
	2.2.5 Sockets	
	2.3 Qualified personnel	
	2.4 Liability	
	Description .....	
<b>3</b>	3.1 Intended use	11
	3.2 Overview	
	3.2.1 Electric pump unit	
	3.2.2 LED indicators (electric pump unit)	
	3.2.3 Pneumatic pump unit	
	3.2.4 Hydraulic socket wrench	
	Installation .....	
<b>4</b>	4.1 Hydraulic hoses	16
	4.1.1 Hydraulic hose connections	
	4.1.2 Connecting the hydraulic hoses	
	4.1.3 Disconnecting the hydraulic hoses	
	4.2 Power supply (electric pump units)	
	4.2.1 Connecting the power supply (115V)	
	4.2.2 Connecting the power supply (230V)	
	4.2.3 Connecting the power supply (400V)	
	4.3 Air supply (pneumatic pump units)	
	4.4 Explosion protection (pneumatic pump units)	
<b>5</b>	Reaction arms .....	21
	5.1 Reaction arm types	

<b>6</b>	Sockets .....	22
6.1	Securing the socket (type 1)	
6.2	Securing the sockets (type 2)	
<b>7</b>	Operation .....	23
7.1	Inspections before use	
7.2	Remote control	
7.2.1	Electric pump unit	
7.2.2	Pneumatic pump unit	
7.3	Reaction pawl - Disengagement lever	
7.4	Torque	
7.4.1	Pressure/torque chart	
7.4.2	Setting the torque	
7.5	Direction of rotation	
7.5.1	Determining the direction of rotation	
7.5.2	Changing the direction of rotation	
7.6	Tightening and loosening a bolted flange connection	
7.6.1	Tightening a bolted flange connection	
7.6.2	Loosening a bolted flange connection	
7.7	Automatic shutoff system	
7.8	Thermal protection	
<b>8</b>	Maintenance .....	29
8.1	Preventive maintenance	
8.2	Maintenance by HYTORC	
<b>9</b>	Storage .....	30
9.1	Storing the cables	
<b>10</b>	Troubleshooting .....	31
<b>11</b>	Tests .....	34
<b>12</b>	XLT dimensional data .....	36
<b>13</b>	MXT dimensional data .....	38
<b>14</b>	MXT-SA dimensional data .....	40
<b>15</b>	Bolt / Torque / HYTORC .....	42
<b>16</b>	Square / Allen drive working torque .....	43
<b>17</b>	Customer service policy .....	44

# 1 About the document

## 1.1 Purpose of the document

The document shows the information to do these steps:

- Install the equipment
- Operate the equipment
- Maintain the equipment

The document contains the original instructions for the XLT, MXT, & MXT-SA hydraulic systems, which is referred with the term 'tool'. The term 'equipment' is used as a more general term to refer to the entire system: the tool, its parts and its accessories, including the pump unit.

## 1.2 How to work with the document

1. Read the document completely. Make sure that you understand all the instructions.
2. Obey the safety instructions to prevent injury or damage to equipment.
3. Perform the procedures completely and in the given sequence.
4. Keep a copy of the latest version of the document and all related documents near the equipment.



## 1.3 Languages

The original language of the document is English. All other language versions are translations of the original instructions.

## 1.4 Illustrations

It is not always possible to provide a detailed illustration of every single item of the equipment. The illustrations in the document show a typical setup and are for instructional use only.

## 1.5 Safety symbols in the document

Safety symbol	Function	Description
	Warning	"Warning" means that injury or death is possible if you do not obey the instructions.
	Caution	"Caution" means that damage to equipment is possible if you do not obey the instructions.
	Note	"Note" is used to give additional information.

1.6 Related documents

<b>Document name</b>	<b>Target Group</b>
XLT/MXT/MXT-SA series operations manual	Personnel who operates the equipment.

1.7 Revision history

<b>Date</b>	<b>Revision Number</b>	<b>Comment</b>
01-03-2018	003	8th Edition

1.8 Contact information

HYTORC  
333 Route 17N  
Mahwah, New Jersey 07430  
1-800-FOR-HYTORC  
Tel: 201-512-9500  
E-Mail: [info@HYTORC.com](mailto:info@HYTORC.com)  
Web: [www.HYTORC.com](http://www.HYTORC.com)

## 2 Safety

### 2.1 General safety instructions

#### 2.1.1 Personnel

- Do not allow unqualified personnel to perform tasks on or with the equipment.
- Keep unqualified personnel, children and animals away from the equipment.
- Wear personal protective equipment (PPE): safety helmet, safety goggles, hearing protection, safety gloves, safety shoes and coverall.
- Keep loose clothing, long hair, and jewelry away from the moving parts.
- Stay alert. Use common sense. Do not use the equipment under the influence of mood-altering substances.
- Always stand in a firm position.
- Do not hold the tool during operation.
- Keep your hands away from the nut or the bolt being loosened or tightened.
- Do not stand in the line of movement of the tool during operation. If the tool separates from the nut or the bolt, it will detach in that direction.
- Be aware that a fastener that breaks during operation may become a high-velocity projectile.
- Make sure that the tool and the pump unit are operated by the same operator. If the tool and the pump unit cannot be operated by the same operator, make sure that good communication is maintained between the operators.
- Obey the local labor and safety laws and environmental regulations.

#### 2.1.2 Work area

- Keep the work area clean and well lit.
- Keep the work area free of unwanted obstacles. Ensure free passages in the work area during operation.

#### 2.1.3 Equipment

- Only use equipment that is approved by HYTORC.
- Only use equipment that is appropriate or compatible with the HYTORC equipment.
- Do not modify the equipment in any way.
- Only use the tools for the purposes for which they have been designed. Do not force small tools or accessories to do the job of a larger tool. HYTORC can develop customized accessories to ensure safe and simple operation. Contact your local HYTORC representative for more information.
- Inspect the equipment for visual damage before each use. Obey the instructions for maintenance of the equipment.
- Do not remove or disable the safety provisions on the equipment.
- Make sure that the cover plates are not damaged and installed correctly. All HYTORC tools are equipped with cover plates to cover moving parts. If cover plates are missing or damaged, contact your local HYTORC representative for repair.
- In most cases, the tool will allow hands-free operation. If the tool must be held or steadied during operation, use alternative means of securing the tool to the application.
- Do not apply more pressure to the equipment than the maximum allowable pressure.
- Do not hit reaction arms or sockets with heavy objects (e.g. hammers). If the nut or the bolt does not turn with the tool you are using, use a tool of a larger size.

- Do not cut, weld, or otherwise modify reaction arms or sockets.
- Do not expose reaction arms or sockets to extremely high or low temperatures.
- Do not leave tools with reaction arms and sockets hanging on the nut or the bolt.
- Do not use pump units, hydraulic hoses, hose connections with hose couplings, power cables or remote control cables to carry or move the equipment. Always hold the pump unit or the tool to carry or move the equipment.
- Store tools and accessories which are not in use properly.

## 2.2 Additional safety instructions

### 2.2.1 Pump units

- Only use HYTORC pump units.
- Do not modify the pump unit in any way.
- Do not use the electric pump unit in atmospheres which are potentially volatile. If there is doubt, use a pneumatic pump unit. Metal-to-metal contact can cause sparks. Take appropriate additional measures.
- Make sure that the maximum operating pressure of the pump unit is not higher than the maximum permitted pressure of 10,000 PSI (700 bar).
- Make sure that the pump unit is properly grounded.
- Make sure that the pump unit is filled with the (supplied) hydraulic oil (Shell Tellus S2 V32).
- Make sure that the oil level in the oil tank is between the minimum mark and the maximum mark. Use the oil level sight glasses to check the oil level.
- To refill the oil tank with hydraulic oil, use only high-grade hydraulic oil (ISO VG 32 or ISO VG 46).
- Do not mix different grades of hydraulic oil.
- Make sure that the oil filler cap is placed on the oil filling point.

### 2.2.2 Electric pump units

- Make sure that the mains voltage corresponds to the rated voltage of the pump unit.
- For 115V pump units, the mains voltage must be between 105V and 125V.
- For 230V pump units, the mains voltage must be between 200V and 230V.
- For 400V pump units, the mains voltage must be between 380V and 460V.
- If you use a 400V pump unit, make sure that the direction of rotation is correct. When the LED indicator becomes red, the direction of rotation is incorrect. Reverse the polarity of the phase inverter plug.
- If you use an extension cable:
  - Do not use an extension cable longer than necessary.
  - Make sure the extension cable is at least 12 awg and 25 ft. in length \*  
\*refer to extension cord chart on HYTORC.com.
  - Fully unroll the extension cable from the cable drum.
  - Make sure that there is no over-voltage or under-voltage.
  - Do not use extension cables that are too thin or too long.

### 2.2.3

#### Hydraulic hoses

- Only use HYTORC hydraulic hoses.
- Do not modify the hydraulic hoses in any way.
- Make sure that the hydraulic hoses are securely connected and not kinked or twisted.
- Keep the hydraulic hoses away from the reaction point.



- Replace damaged hydraulic hoses immediately.
- Replace the hydraulic hoses at least every three years.

## 2.2.4

### Reaction arms

- Only use HYTORC reaction arms.
- Do not modify the reaction arms in any way.
- Place the reaction arm against a solid reaction point that can handle the load.
- Make sure that the reaction point is at least 0.4" (10 mm) from the end of the reaction arm. If a distance of at least 0.4" (10 mm) is not possible, choose another reaction point or contact HYTORC to find an appropriate reaction fixture.

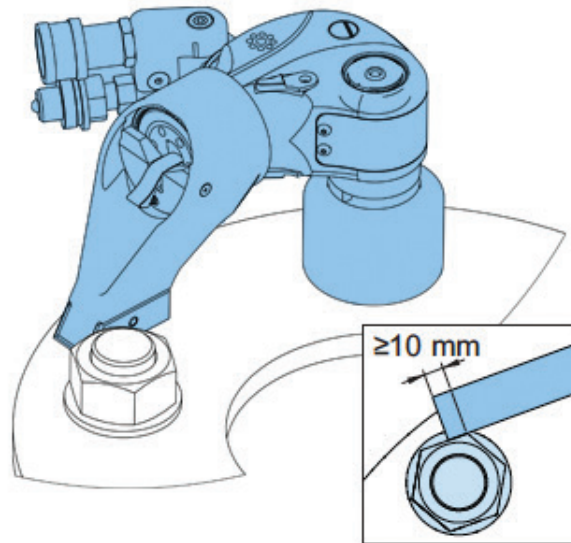

- Make sure that the reaction arm is locked onto the spline of the tool.
- Avoid excessive play. Pressurize the system momentarily. If the tool tends to creep or stand askew, stop immediately and adjust the reaction arm to a more solid and secure position.
- Do not place the reaction arm against a round or inclined reaction point.
- Do not place any part of your body between the reaction arm and the reaction point.

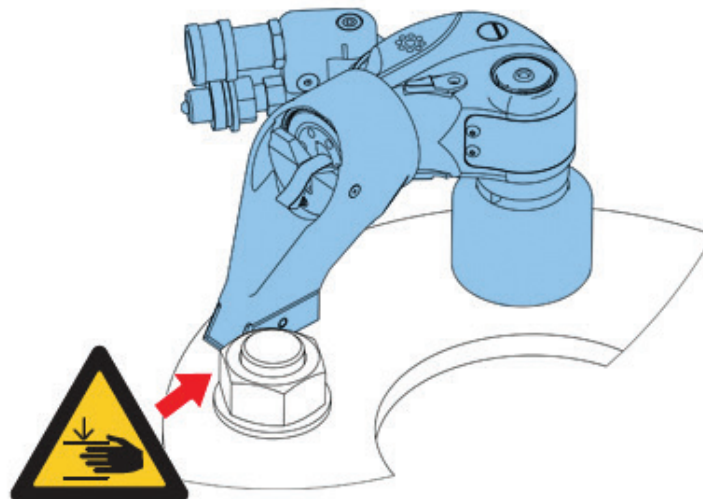

- Do not place objects between the reaction arm and the reaction point.

### 2.2.5 Sockets

- Only use HYTORC sockets.
- Do not modify the sockets in any way.
- Do not use sockets that have been excessively heated or cooled.
- Use thick-walled heavy-duty sockets only. Do not use thin-walled sockets.
- Use 12-point sockets only if necessary.
- Do not use sockets that are used on impact wrenches. The impact deforms the drive hole of the socket which hardens and brittles the steel. This can cause fracture of the steel and increases the risk of flying objects.
- Make sure that the width across flats of the socket corresponds to the width across flats of the nut or the bolt. Note the difference between metric and imperial measurements.
- Place the tool with the socket on the nut or the bolt. Make sure that the socket is placed over the nut or the bolt as far as possible.
- Make sure that the socket is secured to the tool.
- Do not use common extension pieces or step-up/step-down adapters. HYTORC can develop customized accessories to ensure safe and simple operation. Contact your local HYTORC representative for more information.

### 2.3 Qualified personnel

The term 'qualified personnel' refers to persons who thoroughly understand the equipment and its safe installation, operation and maintenance. Qualified personnel are physically capable of performing the required tasks, familiar with all relevant safety instructions and regulations and trained to safely install, operate and maintain the equipment. It is the responsibility of the company operating the equipment to see that the personnel meet these requirements.

### 2.4 Liability

HYTORC cannot be held responsible for injury or damage that results from unintended use of the equipment. The equipment is designed and intended only for the purpose described in the relevant documents. Uses not described in the relevant documents are considered unintended uses and can result in injury or damage.

Unintended uses include:

- Using equipment that is not approved by HYTORC
- Using equipment that is inappropriate or incompatible with the HYTORC equipment
- Altering or modifying equipment in any way
- Allowing unqualified personnel to perform tasks on or with the equipment

### 3 Description

#### 3.1 Intended use

The XLT, MXT, & MXT-SA are bolting systems used for both torque and tension applications. Various reaction arms and sockets are available from HYTORC for use with the tool. HYTORC hydraulic tools have an accuracy of  $\pm 3\%$ .

#### 3.2 Overview

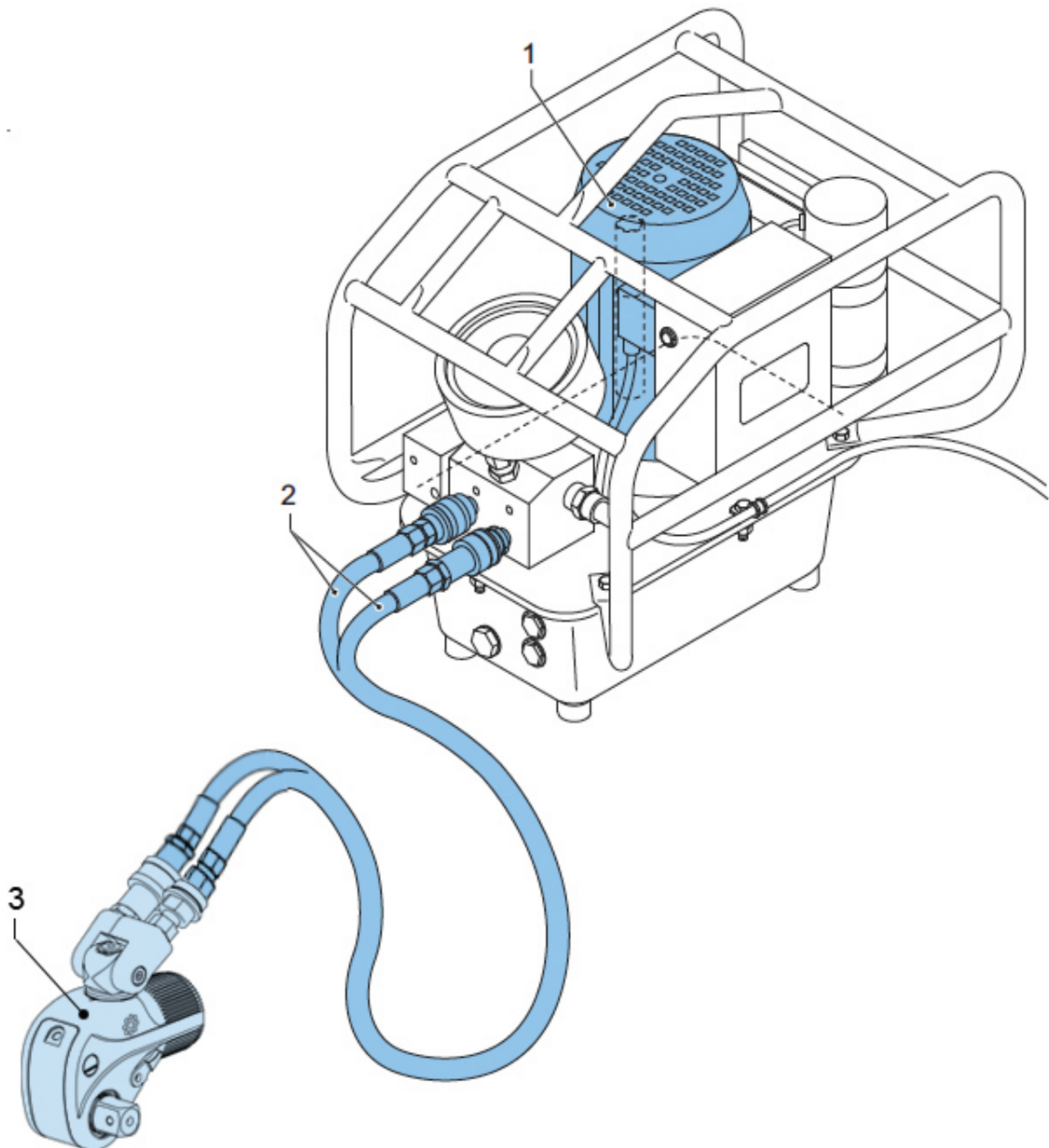

1. Electric pump unit
2. Twin hose
3. Hydraulic wrench

### 3.2.1 Electric pump unit

The pressure range of the pump unit is 1500 PSI - 10,000 PSI (100 bar - 700 bar).

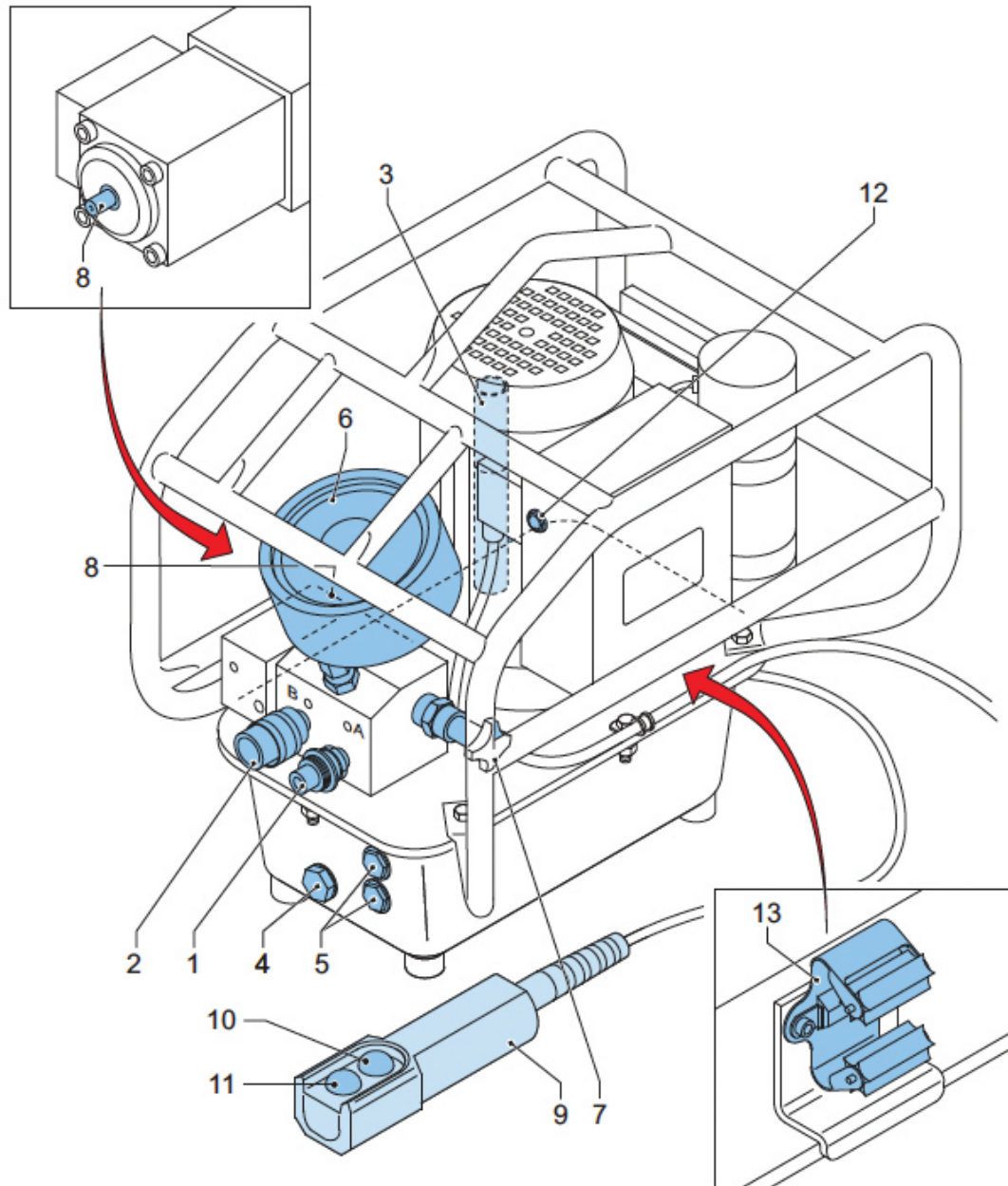

1. Hose connection (male coupling) (supply hose) (A)
2. Hose connection (female coupling) (return hose) (B)
3. Oil filling point
4. Oil drain point
5. Oil level sight glass
6. Pressure gauge
7. Pressure control valve
8. Pressure relief valve
9. Remote control
10. Start button
11. Stop button
12. LED indicator
13. Remote control clamp

## 3.2.2

## LED indicators (electric pump unit)

## 115V and 230V pump unit

Indication	Description
Green, continuous	The pump unit is ready for use.

## 400V pump unit

Indication	Description
Green, continuous	The pump unit is ready for use.
Red, flashing (2x)	The direction of rotation is incorrect. Reverse the polarity of the phase inverter plug.
Red, continuous	Error.

### 3.2.3 Pneumatic pump unit

The pressure range of the pump unit is 1500 PSI - 10,000 PSI (100 bar - 700 bar).

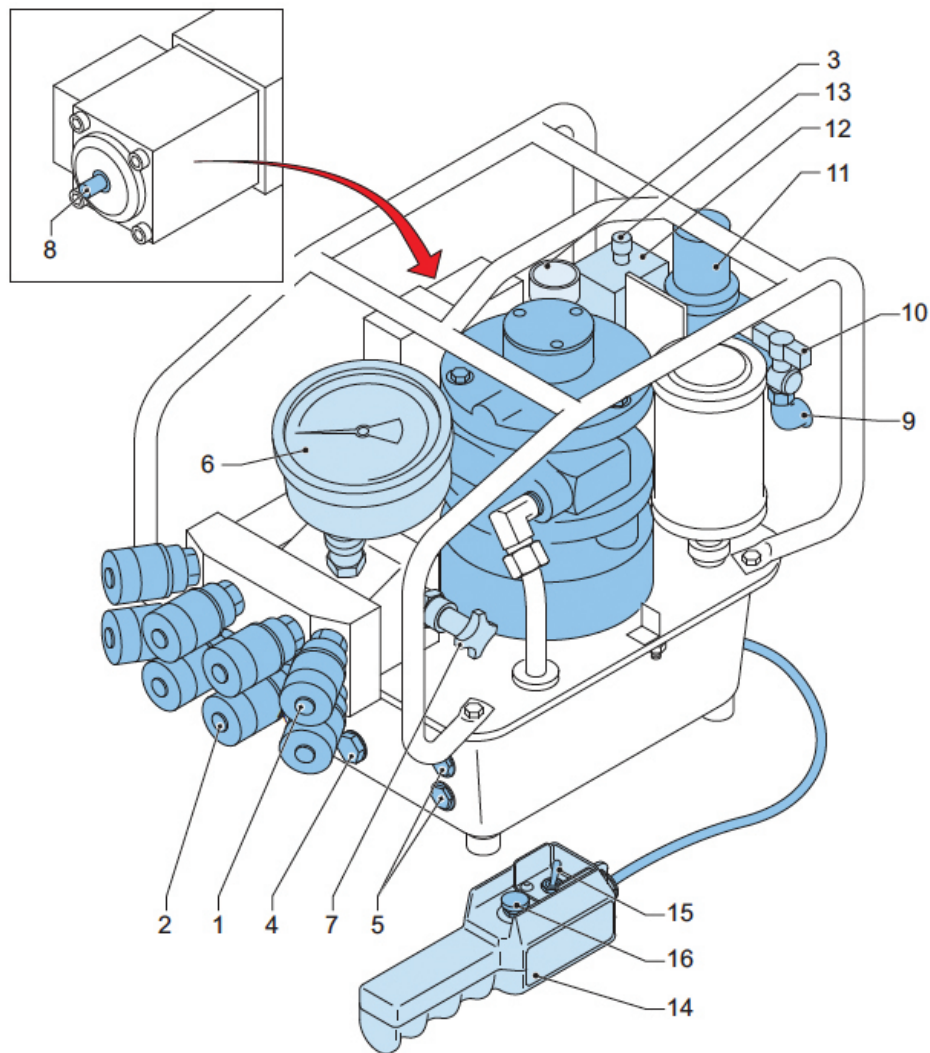

1. Hose connection (male coupling) (supply hose)
2. Hose connection (female coupling) (return hose)
3. Oil filling point
4. Oil drain point
5. Oil level sight glass
6. Pressure gauge
7. Pressure control valve
8. Pressure relief valve
9. Compressed-air inlet
10. Air shutoff valve
11. Water filter / Air pressure regulator
12. Air lubricator
13. Filter cap
14. Remote control
15. On/off switch
16. Start button

## 3.2.4 Hydraulic wrench

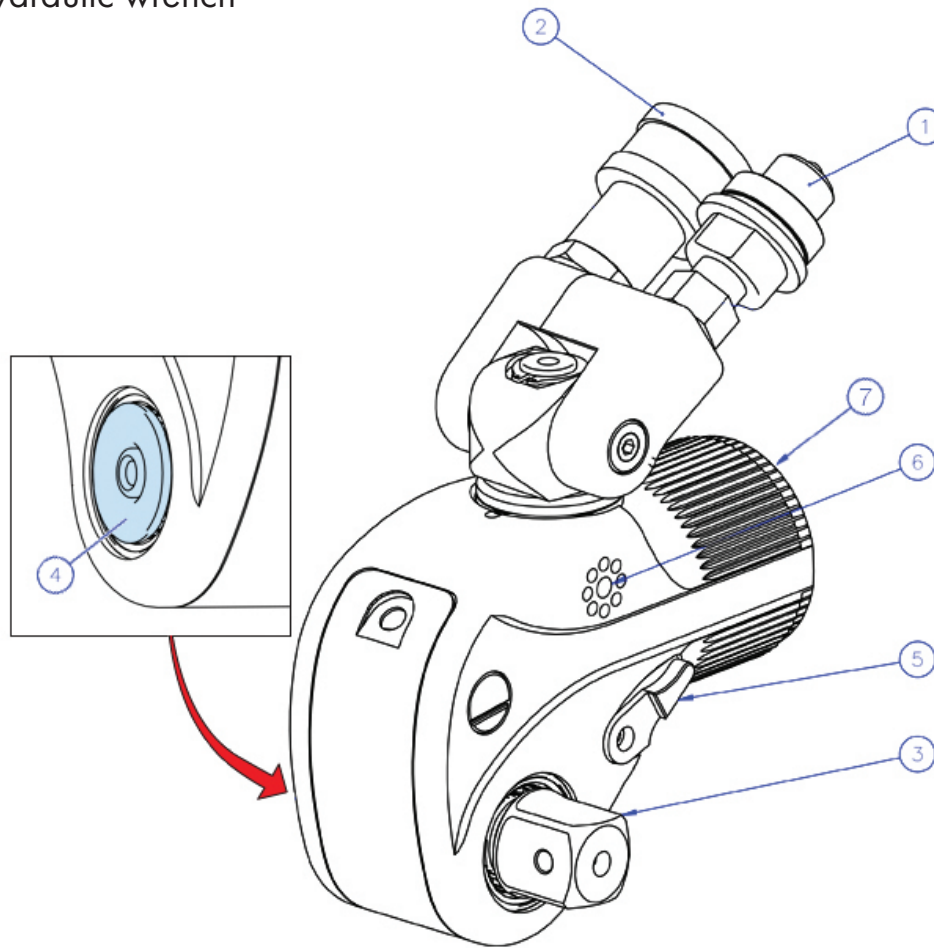

1. Hose connection (male coupling) (supply hose)
2. Hose connection (female coupling) (return hose)
3. Square drive for socket connection
4. Drive retainer
5. Disengagement lever
6. Mounting point for safety handle
7. Spline for connection of reaction arm

## 4 Installation

### 4.1 Hydraulic hoses

The working pressure of the hydraulic hoses is 10,000 PSI (700 bar). The safety factor of the hydraulic hoses is 4:1.

#### 4.1.1 Hydraulic hose connections

Use a twin hose to connect the pump unit to the tool. A twin hose consists of two hoses.

The supply hose has two ends with female couplings. The supply hose is connected to the hose connections with male couplings on the pump unit and the tool. The male coupling on the pump unit is marked with "A". The male coupling on the tool is marked with "A".

The return hose has two ends with male couplings. The return hose is connected to the hose connections with female couplings on the pump unit and the tool. The female coupling on the pump unit is marked with "B". The male coupling on the tool is marked with "R".



**Caution:** Do not modify the hydraulic hoses in any way. If you modify the hydraulic hoses, damage to the equipment can occur.

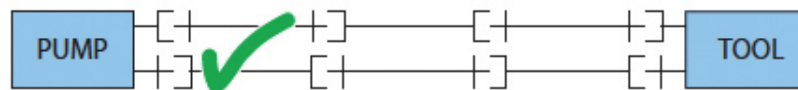

**Note:** An odd number of hoses is required to extend the hydraulic hose. You cannot use an even number of hoses. "PUMP" refers to the electric pump unit. "TOOL" refers to the tool.



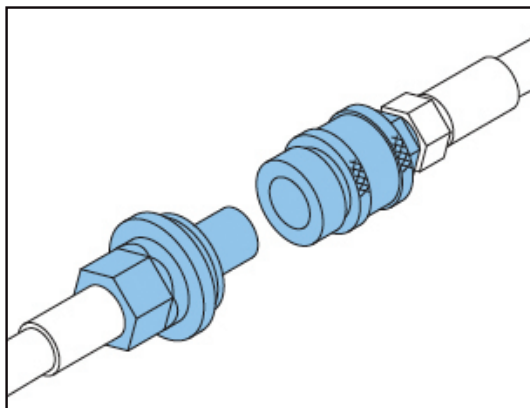

### Screw-type safety couplings

- To tighten the couplings, make sure that the system is depressurized. Push the couplings completely together to full engagement, and tighten the locking ring of the female coupling to the male coupling. If the couplings are not fully tightened, the tool will not operate.
- To loosen the couplings, make sure that the system is depressurized. Loosen the locking ring of the female coupling from the male coupling and pull the couplings apart.

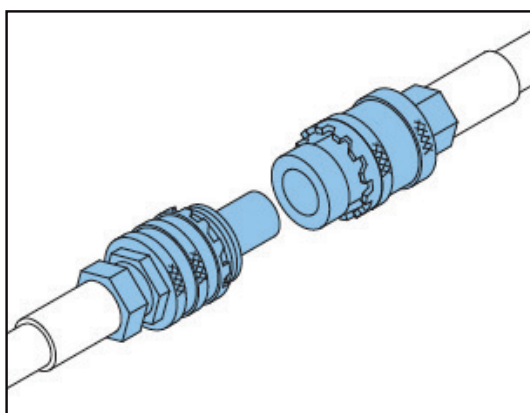

### Toothed screw-type safety couplings

The coupling is identical to the screw-type safety couplings, but both coupling are toothed. The male coupling has a toothed locking ring which is axially displaceable. The female coupling also has a toothed ring.

- To tighten the couplings, make sure that the system is depressurized. Push the couplings together and engage the teeth of male coupling and the female coupling. If the couplings are not fully tightened, the tool will not operate.
- To loosen the couplings, make sure that the system is depressurized. Pull the toothed locking ring axially and loosen the locking ring.

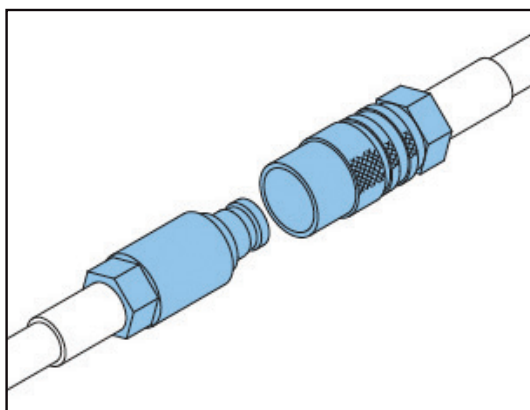

### Quick couplings

- To tighten the couplings, make sure that the system is depressurized. Pull back the pullback ring on the female coupling, push the male coupling into the female coupling and release the pullback ring. Screw the locking ring on the female coupling against the pullback ring.
- To loosen the couplings, make sure that the system is depressurized. Screw the locking ring on the female coupling from the pullback ring. Pull back the pull-back ring to remove the male coupling from the female coupling.

## 4.1.2 Connecting the hydraulic hoses



### Warning:

- Make sure that the system is depressurized.
- Make sure that the hydraulic hoses are securely connected to both the pump unit and the tool. Make sure that there is no clearance between the male couplings and the female couplings. If the hydraulic hoses become loose, no hydraulic oil will flow through the hoses and the tool will not operate.

1. If the hose couplings are dirty, clean them with a lint-free cloth.
2. Fully tighten the female couplings to the male couplings.
3. Manually tighten the hose couplings. Do not use pliers.

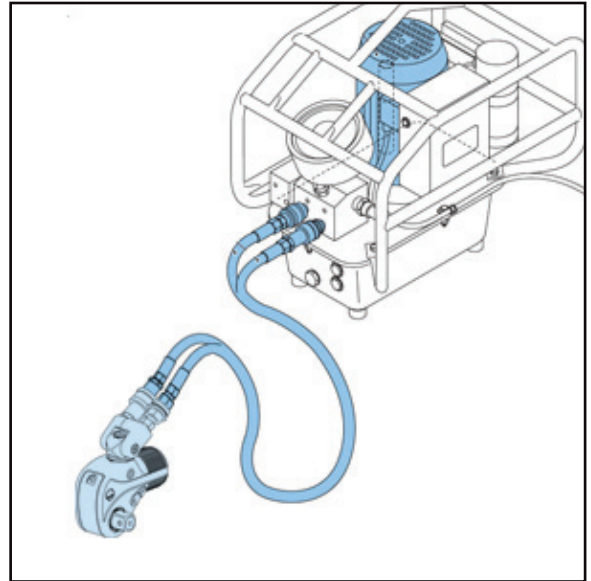

### 4.1.3 Disconnecting the hydraulic hoses



**Warning:**

- Make sure that the system is depressurized.

1. Disconnect the return hose from the pump unit and the tool.
  - If you cannot disconnect the return hose, press and hold the stop button (B) and press the start button (A) on the remote control.
  - If you still cannot disconnect the return hose, there is residual pressure in the hose. Press the pressure relief valve (C) on the pump unit to depressurize the hose.
2. Disconnect the supply hose from the pump unit and the tool.
3. Roll up the hydraulic hoses and connect the hose couplings to prevent them from becoming soiled.

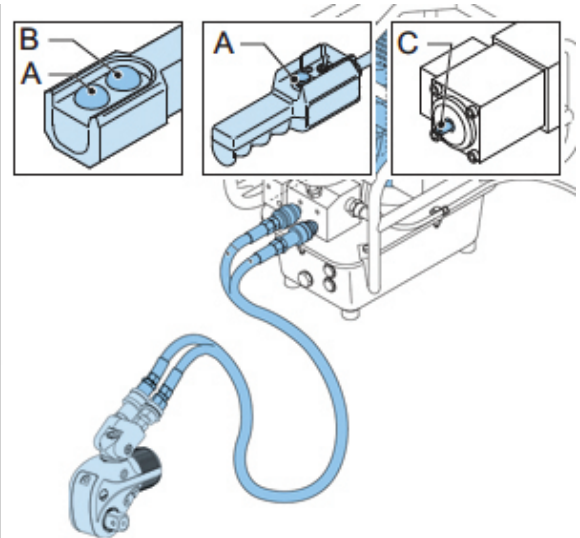

### 4.2 Power supply (electric pump units)

There are different types of electric pump units to operate the tool:

1. 115V pump unit
2. 230V pump unit
3. 400V pump unit

## 4.2.1

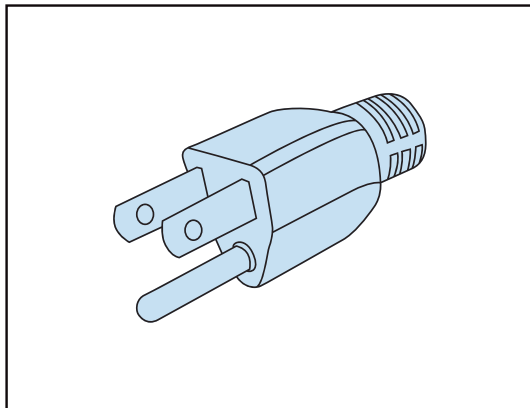

## Connecting the power supply (115V)

1. Connect the mains plug to the wall socket.
2. Use an extension cable that is as short as possible.
3. Make sure the extension cable is at least 12 awg and 25 ft. in length\*

\*refer to extension cord chart on [HYTORC.com](http://HYTORC.com)

## 4.2.2

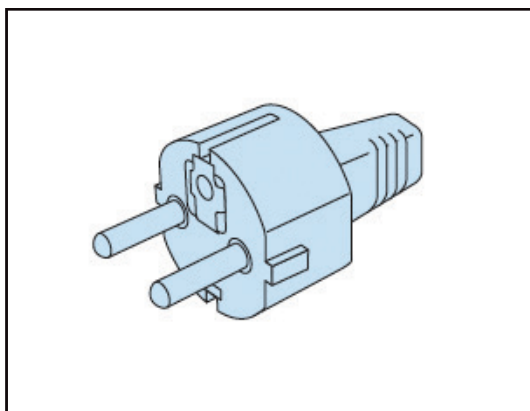

## Connecting the power supply (230V)

1. Connect the mains plug to the wall socket.
2. Use an extension cable that is as short as possible.
3. Make sure the extension cable is at least 12 awg and 25 ft. in length\*

\*refer to extension cord chart on [HYTORC.com](http://HYTORC.com)

## 4.2.3

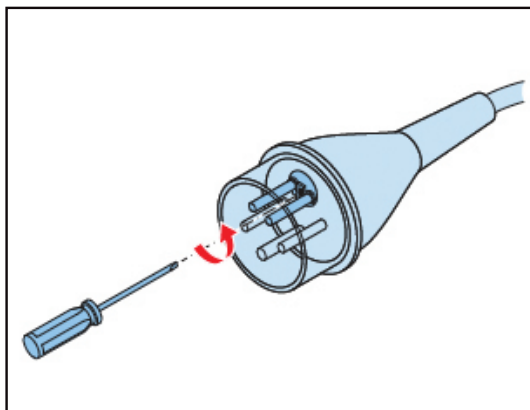

## Connecting the power supply (400V)

1. Connect the mains plug to the wall socket.
2. If the pump does not start to operate, use a thicker or shorter extension cable.
3. Make sure that the direction of rotation is correct. If the LED indicator on the pump unit lights red, the direction of rotation is incorrect. Reverse the polarity of the phase inverter plug.
  - a) Place a flat-head screwdriver as shown.
  - b) Turn the insulated plate 180° to reverse the polarity of the phase inverter plug.

4.3

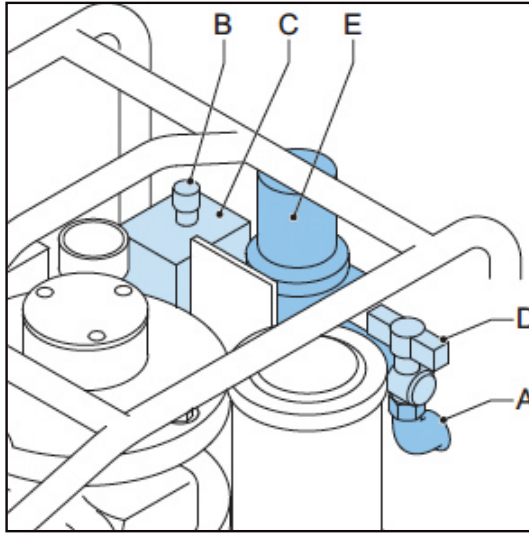

**Air supply (pneumatic pump units)**

1. Connect an air hose to the compressed-air inlet
2. It is recommended to use a filter regulator lubricator (FRL):
  - a) Remove the filter cap (B).
  - b) Fill the air lubricator (C) halfway with hydraulic oil. Use only high grade hydraulic oil (ISO VG 32 or ISO VG 46).
  - c) Install the filter cap (B).
  - d) Open the air shutoff valve (D).
  - e) Turn the air pressure regulator (E) to adjust the air lubricator (C) to one drop per 60-90 seconds.
  - f) Close the air shutoff valve (D).

4.4

**Explosion protection (pneumatic pump units)**

Several solid metal springs ensure conductivity of the entire system.



**Warning:**

- Only use ATEX-certified pneumatic pump units, hydraulic hoses and tools in areas with explosion hazard.
- Let authorized personnel inspect the explosion-proof system on a regular basis.

1. Make sure that all couplings and other connections are tight.
2. Connect a multimeter between the tool and one end of a grounding wire to measure the conductivity.
3. Connect one end of the grounding wire to the pneumatic pump unit.
4. Connect the other end of the grounding wire to an earthing point.

## 5 Reaction arms

There are different types of reaction arms to operate the tool. For additional convenience and operator safety, install the safety handle to the tool.

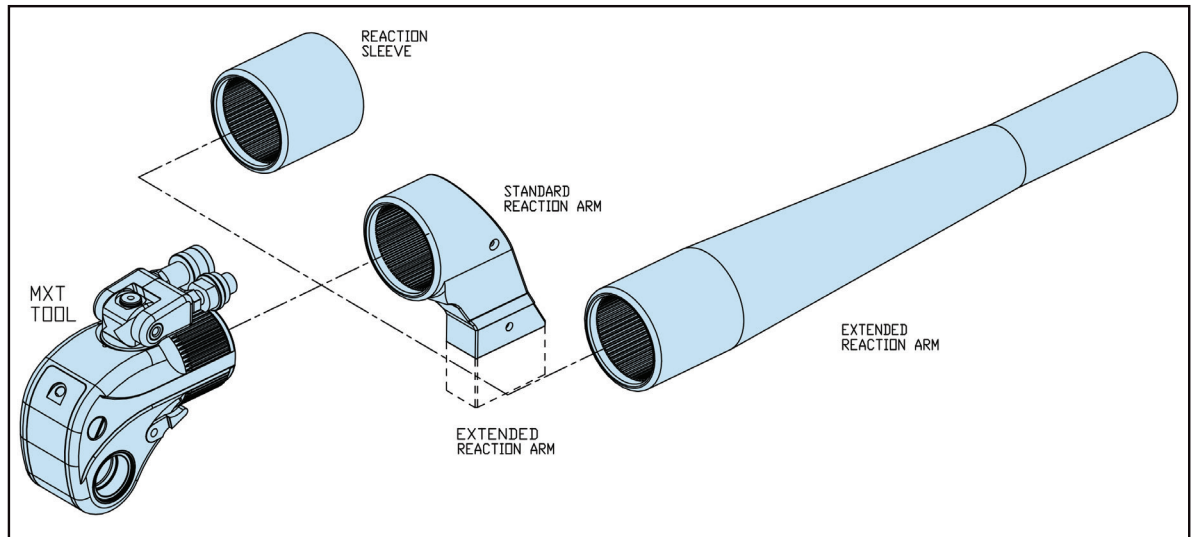

### 5.1 Reaction arm types

The XLT, MXT, and MXT-SA have an extensive range of reaction arms for different scenarios. The image above shows the most common types of reaction arms which vary in both length and size. Please contact your local HYTORC representative for all available options.

## 6

## Sockets

There are different types of heavy-duty sockets to use with the tool:

1. 6-point sockets / 12-point sockets (regular / high)
2. 6-point Allen sockets / 12-point Allen sockets (regular / high)
3. Eccentric sockets
4. Customized sockets

The heavy-duty sockets are available in the sizes  $\frac{1}{2}$ ,  $\frac{3}{4}$ , 1,  $1\frac{1}{2}$ ,  $2\frac{1}{2}$  and  $3\frac{1}{2}$ .

**Warning:**

- Do not use sockets that are used on impact wrenches.

## 6.1

## Securing the socket (type 1)

1. Slide the securing pin (B) into the socket (A) as shown.
2. Fit the rubber ring (C) to the socket (A) as shown.

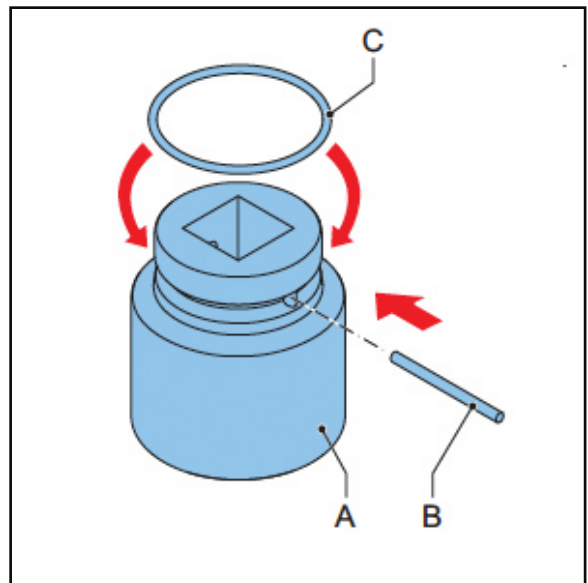

## 6.2

## Securing the sockets (type 2)

1. Fit the securing clip (B) to the socket (A) as shown.

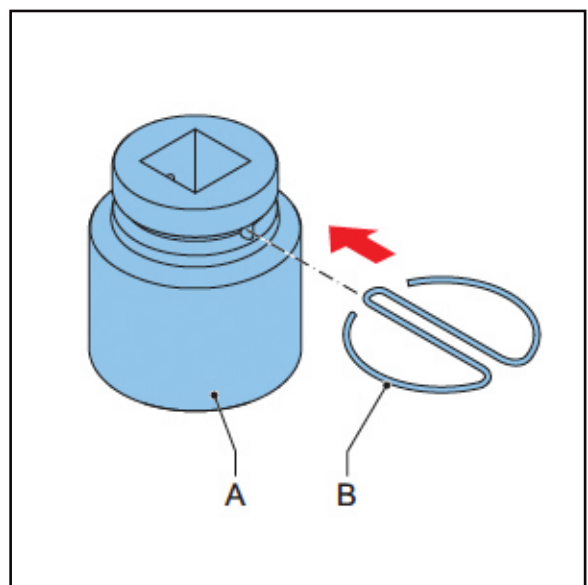

## 7 Operation

### 7.2 Check the following items before each use:

- Oil level in the oil tank is between the minimum mark and the maximum mark.
- Power supply is correct.
- Power cable is fully unrolled and not kinked, twisted, or damaged.
- Remote control cable is fully unrolled and not kinked, twisted or damaged.
- All couplings and other connections are tight and not damaged or deformed.
- Hydraulic hoses are securely connected, not kinked, twisted, or damaged. Inspect the hydraulic hoses for damage with a set pressure of 2,900 PSI (200 bar), 5,800 PSI (400 bar) and 10,000 PSI (700 bar) respectively.
- All moving parts of the tool are clean and sufficiently lubricated with a high-quality NLGI #2 molybdenum disulfide grease.
- Square drive and the drive retainer are securely fitted.
- Reaction arm is placed against a solid reaction point and secured to the tool.
- Socket has the correct size and is secured to the tool.
- All securing clips, securing pins and securing screws are fitted and secured to the pump unit, hydraulic hoses, the tool, the reaction arm and the socket.
- All water, if present, is drained from the water separator (pneumatic pump units only).
- Pressure gauge does not leak. Signs of leakage are a decrease in the level of glycerin in the pressure gauge or the pressure gauge filled with hydraulic oil.

### Remote control

#### 7.2

#### Electric pump unit

##### 7.2.1

1. Press the start button (A) on the remote control to switch on the pump unit.
2. Press and hold the start button (A) on the remote control to increase the pressure in the pump unit and operate the tool.
3. Press the stop button (B) on the remote control to switch off the pump unit.

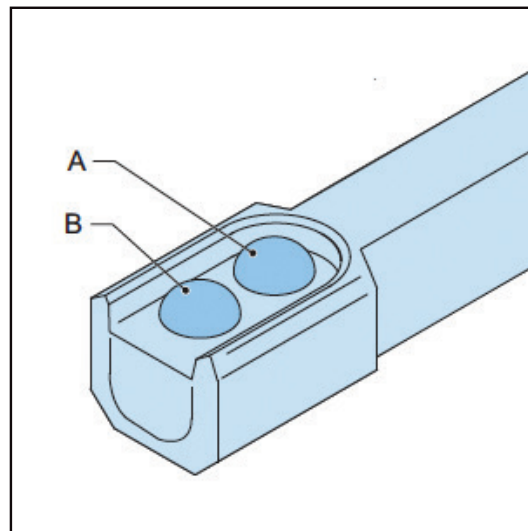

## 7.2.2 Pneumatic pump unit

1. Set the on/off switch (A) to the on position to switch on the pump unit.
2. Press and hold the start button (B) to increase the pressure in the pump unit and operate the tool.
3. Set the on/off switch (A) to the off position to switch off the pump unit.

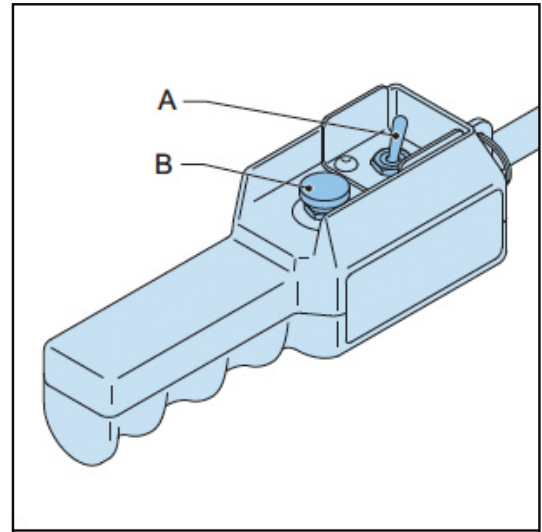

## 7.3 Reaction pawl - Disengagement lever

1. Move the disengagement lever to position B.
2. Press and hold the start button on the remote control until the set pressure is reached.
3. Remove the tool from the nut or the bolt.
4. Move the disengagement lever to position A.

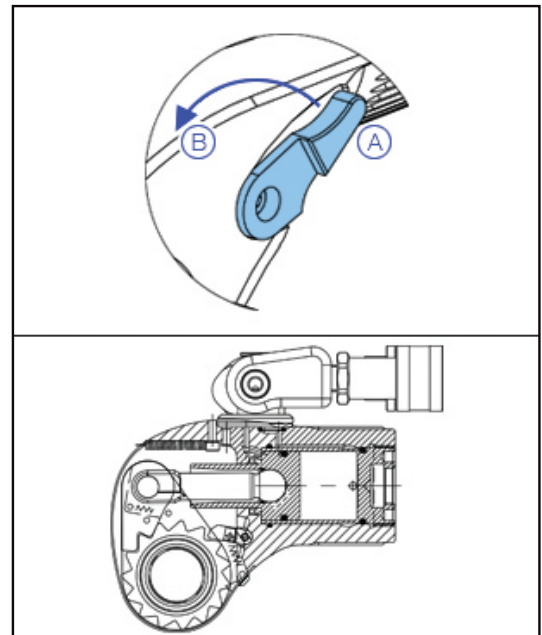

## 7.4 Torque

### 7.4.1 Pressure/torque chart

The maximum operating pressure for all HYTORC pump units is 10,000 PSI (700 bar).



#### **Warning:**

- Make sure that the maximum operating pressure of the pump unit is not higher than the maximum permitted pressure of 10,000 PSI (700 bar).

Each HYTORC torque wrench has its own pressure/torque chart. The pressure/torque chart is separately supplied with your HYTORC torque wrench. Refer to the pressure/torque chart to find the required torque (Nm / ft.lb.) and read the required pressure (bar / PSI).



## Example (MXT 3)

Pressure		Torque	
bar	PSI	Nm	ft.-lbs.
104	1,500	651	480
110	1,600	694	512
124	1,800	781	576
138	2,000	868	640
152	2,200	954	704
165	2,400	1041	768
179	2,600	1128	832

## 7.4.2

## Setting the torque

**Warning:**

- Always set the pressure from low pressure to high pressure.

1. Loosen the wingnut on the pressure control valve (A) of the pump unit.
2. Turn the pressure control valve (A) counterclockwise to set the pressure as low as possible.
3. Put the tool on the ground or on another safe location.
4. Start the pump:

- Electric pump unit: Press the start button (B) on the remote control.
- Pneumatic pump unit: Set the on/off switch (D) to the on position.

The pump starts to operate. The piston in the tool moves to the fully retracted position.

5. Press and hold the start button (B) on the remote control until the square drive no longer turns. The piston in the tool is in the fully extended position.

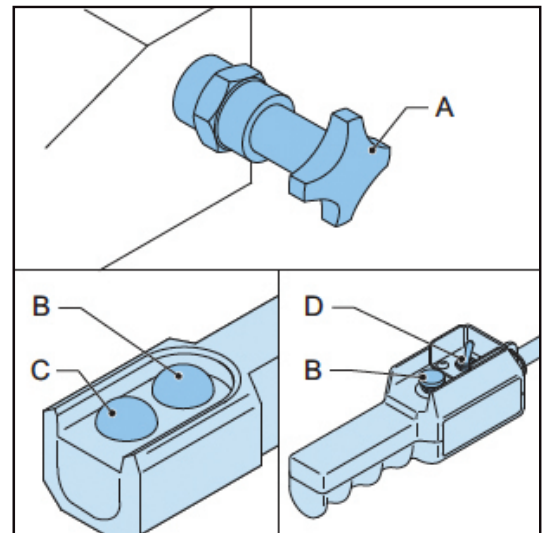
**Note:**

- If the piston does not move, turn the pressure control valve (A) 360°

6. Release the start button (B) on the remote control. The piston in the tool moves to the fully retracted position.
7. Repeat steps 4 through 6 three times.

8. Set the correct torque.
  - a) Press and hold the start button (B) on the control.
  - b) Turn the pressure control valve (A) until the pressure gauge shows the correct pressure.
  - c) Release the start button (B) on the control.
  - d) After a few seconds, press and hold the start button (A) on the remote to check the pressure.
  - e) If the pressure is correct, tighten the wingnut on the control valve (A) of the pump unit.
  - f) After a few seconds, press and hold the start button (A) on the control to check the pressure.

## 7.5 Direction of rotation

### 7.5.1 Determining the direction of rotation

1. To tighten a bolted connection, place the tool onto the bolt as shown. Refer to the marking "TIGHTEN" on the tool.
2. To loosen a bolted connection, place the tool onto the bolt as shown. Refer to the marking "LOOSEN" on the tool.

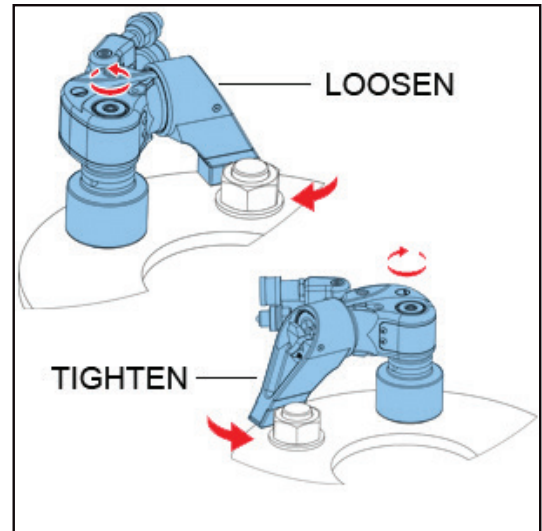

### 7.5.2 Changing the direction of rotation

1. Press and hold the button on the drive retainer (A) and pull the square drive (B) to remove it from the tool.
2. Remove the drive retainer (A).
3. Place the drive retainer (A) on opposite side of the tool.
4. Press and hold the button on the drive retainer (A) and insert the square drive (B) into the opposite side of the tool.
5. Release the button on the drive retainer (A).

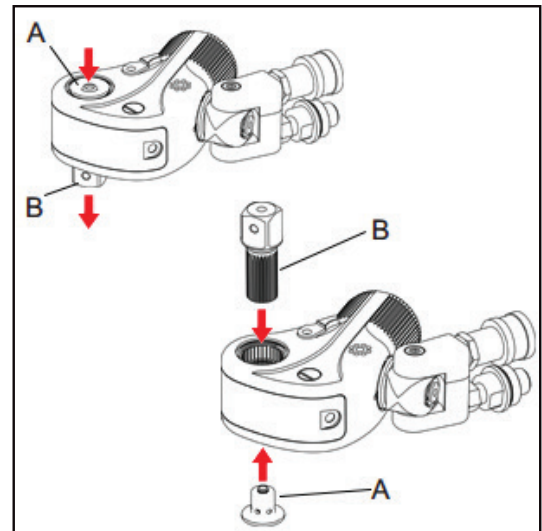

## 7.6 Tightening and loosening a bolted flange connection



### Warning:

- Place the tool with the socket on the nut or the bolt. Make sure that the socket is placed over the nut or the bolt as far as possible. Obey the safety instructions for sockets.
- Place the reaction arm against a solid reaction point that can handle the load. Obey the safety instructions for reaction arms.
- Make sure that the hydraulic hoses are securely connected. Obey the safety instructions for hydraulic hoses.
- Make sure that the hydraulic hoses are free of the reaction point and other obstructions.
- Pressurize the system momentarily. If the tool tends to creep or stand askew, stop immediately, turn off the pump, and adjust the reaction arm to a more solid and secure position.

### 7.6.1 Tightening a bolted flange connection

1. Start the pump unit and set the torque.
2. Place the tool onto the nut or the bolt head correctly. Refer to the marking "TIGHTEN" on the tool.
3. Press and hold the start button (B) on the remote control until the square drive no longer turns. The piston in the tool is in the fully extended position. An audible click will sound. The pressure gauge increases to the set value.

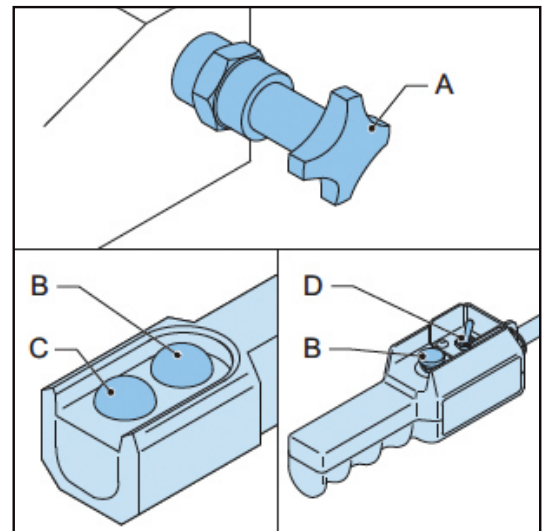

### Note:

If the pressure gauge increases to the set value, this does not indicate that the required torque is applied to the nut or the bolt. It only indicates that the piston in the tool cannot turn the socket further until the tool automatically resets itself.

4. Release the start button (B) on the remote control. The piston in the tool moves to the fully retracted position. An audible click will sound.
5. Repeat steps 3 and 4 until the nut or the bolt no longer turns. The nut or the bolt has been tightened with a torque accuracy of  $\pm 3\%$ .

### 7.6.2 Loosening a bolted flange connection



### Caution:

- Always set the pressure as low as possible to loosen the nut or the bolt.
- If you must constantly use a high pressure to loosen the nut or the bolt, use a larger tool. Contact your local HYTORC representative for more information.

1. Turn the pressure control valve (A) clockwise to set the maximum pressure (10,000 PSI, 700 bar). If you use Allen sockets, there are restrictions to make sure that the sockets do not break.
2. Place the tool onto the nut or the bolt correctly. Refer to the marking "LOOSEN" on the tool.
3. Press and hold the start button (B) on the remote control until the square drive no longer turns. The piston in the tool is in the fully extended position. An audible click will sound. The pressure gauge increases to the set value.
4. Release the start button (B) on the remote control. The piston in the tool moves to the fully retracted position. An audible click will sound.
5. Repeat steps 3 and 4 until you can loosen the nut or the bolt by hand.

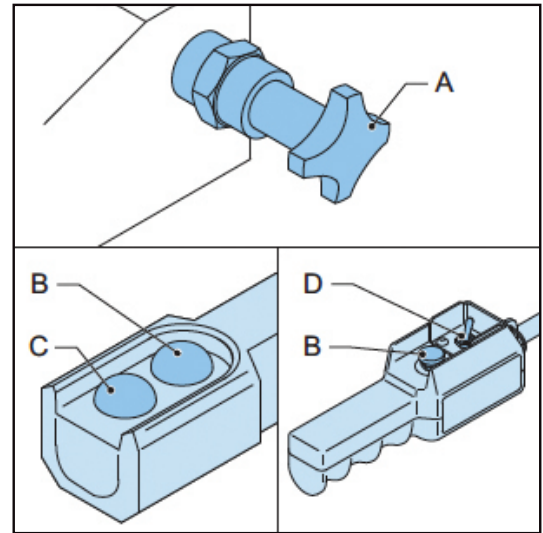

## 7.7

### Automatic shutoff system

The electric pump unit is equipped with an automatic shutoff system. The pump unit will be switched off after approximately 30 seconds of non-operation to prevent wear and overheating. To restart the pump unit, press the start button on the remote control.

## 7.8

### Thermal protection

The electric pump unit is equipped with a thermal protection to monitor the temperature of the motor. If the preset maximum temperature is exceeded, the pump will be switched off automatically and the green LED indicator on the pump unit will turn off.

The green LED indicator on the pump will turn on when the motor has cooled down.

## 8 Maintenance

### 8.1 Preventive maintenance

- Replace the hydraulic oil after every 40 hours of operation or at least twice a year. Use only high-grade hydraulic oil (ISO VG 32 or ISO VG 46).
- Replace the filter of the pump unit at least 3 times a year or more often if the pump unit is used daily or in a dirty environment.
- Electric pump unit: Clean or replace worn carbon brushes of the pump unit.
- Clean dirty hose couplings. Replace defective hose couplings.
- Replace the hydraulic oil when it has a white, milky look.

### 8.2 Maintenance by HYTORC

- Have the tool fully disassembled, cleaned, inspected and lubricated at least once a year.
- Have the pressure gauge calibrated at least once a year.
- Have the rotor shaft and the rotor shaft bearings of the pump motor cleaned and lubricated at least once a year.
- Have the air hose to the remote control inspected for obstructions or kinks periodically.
- Have the spring-loaded buttons on the remote control inspected if they do not operate smoothly.
- Have the pressure control valve of the pump unit cleaned at least once a year.
- Contact HYTORC to learn more about the TORCsafe preventative maintenance program.

## 9 Storage

### 9.1 Storing the cables

1. Wind the remote control cable around the frame.
2. Place the remote control in the remote control clamp.
3. Electric pump unit: Wind the power supply cable around the frame.

# 10 Troubleshooting

Try to find a solution for the problem using the tables. If you cannot find a solution for the problem, contact your local HYTORC representative.

<b>SYMPTOM</b>	<b>PROBABLE CAUSE</b>	<b>REQUIRED ACTION</b>
Gauge shows pressure build-up but the tool will not cycle	<ol style="list-style-type: none"> <li>1. Couplings loose or inoperative</li> <li>2. Solenoid inoperative</li> </ol>	<ol style="list-style-type: none"> <li>1. Tighten and/or replace couplings. Use Test #1 to isolate problem. (pg. 34)</li> <li>2. Check using test #2. (pg. 34) If solenoid is bad, replace.</li> </ol>
Cylinder will not retract.	<ol style="list-style-type: none"> <li>1. See above</li> <li>2. Voltage to electric pump is too low to line drop or inadequate amperage is available.</li> <li>3. Linkage between piston rod and drive arms are broken.</li> </ol>	<ol style="list-style-type: none"> <li>1. See Above</li> <li>2. Get shorter extension cord or upgrade to 12AWG, 25 amp rating or better. If shop power is adequate, draw power from welding machine or cal rod transformer.</li> <li>3. Replace parts as necessary.</li> </ol>
Cylinder pressure will not build.	<ol style="list-style-type: none"> <li>1. Oil blow by in tool (Piston seal leak, blown O-ring, cracked piston)</li> <li>2. Pump Problem</li> </ol>	<ol style="list-style-type: none"> <li>1. Replace defective parts. (Call for service)</li> <li>2. Check to see if sub-plate is worn by; a) Remove screws from pump motor to reservoir, slide Pump motor to the side, turn pump on and while holding down on the button, put your finger on the dump tube (round tube under the directional control valve) - if you feel pressure, then replace the sub-plate and shear seals.                     <ol style="list-style-type: none"> <li>2A. Check to see if you have leaks from the external relief valve and the 2 oil line connections (bottom of relief valve and connection into pump body's other end) of oil line. If leaking, re-tighten with 9/16" open end wrench. (Call for service)</li> <li>2B. If pump sounds like a lot of pebbles in a tin can, the problem may be a worn motor coupling. Remove motor from base plate - using a pair of needle nose pliers remove the motor coupling - if worn, replace. (Call for service)</li> <li>2C. AIR PUMPS - Faulty Air Valve due to excessive moisture and/or dirt in air supply. Disassemble air valve and wipe any residue from air valve piston. Spray brake cleaner into air valve body, dry thoroughly. Disassemble all small air lines and blow out with compressed air. Lubricate both air valve piston and body with hydraulic oil (sparingly) and reassemble. (Call for service)</li> <li>2D. Air pumps - Faulty remote control valve cartridge. Replace.</li> </ol> </li> </ol>

(Continued on following page.)

**10**  
(continued...)

<b>SYMPTOM</b>	<b>PROBABLE CAUSE</b>	<b>REQUIRED ACTION</b>
Cylinder/Tool leaks	<ol style="list-style-type: none"> <li>1. Safety relief valve on swivel has lifted.</li> <li>2. Blown O-ring in cylinder</li> <li>3. Defective gland seal.</li> </ol>	<ol style="list-style-type: none"> <li>1A. Tighten all hose and couplers. If leak continues, adjust safety setting - Test #4 (pg. 34)</li> <li>1B. Check to see if the system is properly plumbed by running test #5 (pg. 34) (high pressure on retract side will lift the safety relief valve)</li> <li>2. Replace O-Ring with proper high pressure O-Ring. (Call for service)</li> <li>3. Replace gland seal. (Call for service)</li> </ol>
Tool operates backwards	<ol style="list-style-type: none"> <li>1. Couplings reversed</li> <li>2. Multiple hoses in even numbers</li> </ol>	<ol style="list-style-type: none"> <li>1. Run test #5. Re-Plumb system as necessary.</li> <li>2. As plumbed, HYTORC hoses may only be joined together in odd numbers ONLY. If it is necessary to use 2,4,6 hoses - make an adapter from spare high pressure couplings and nipples.</li> </ol>
Ratchet returns with retract stroke	<ol style="list-style-type: none"> <li>1. Broken or otherwise inoperable drive segment.</li> </ol>	<ol style="list-style-type: none"> <li>1. Replace drive segment and/or spring. (Call for service)</li> </ol>
Ratchet will not take successive strokes	<ol style="list-style-type: none"> <li>1. Broken or otherwise inoperative drive segment I or spring</li> <li>2. Cylinder not retracting completely</li> <li>3. Linkage between piston rod and drive plates is broken</li> </ol>	<ol style="list-style-type: none"> <li>1. Replace drive segment and/or spring. (Call for service)</li> <li>2. Remove tool from nut and cycle freely for several strokes. If problem persists, check pawls.</li> <li>2A. Operator not allowing adequate time for cylinder to retract fully.</li> <li>3. Replace parts as necessary - (Call for service)</li> </ol>
Tool locks onto nut	<ol style="list-style-type: none"> <li>1. Drive segment is loaded when the tool is maxed out in torque</li> <li>2. Tool is operating backwards</li> <li>3. Tool is wedged under a fixed object</li> </ol>	<ol style="list-style-type: none"> <li>1. Press advance button on remote and build pressure - continue to press down on remote while pulling back on one of the accuracy assurance levers - release remote while continuing to hold back on levers</li> <li>2. Push advance button down - tool should immediately fall free- Run test #5 (pg. 34)</li> <li>3. Remove shroud from around ratchet. Using any tool available, pry the drive segment out of the ratchet and at the same time pull back on the accuracy assurance levers. Tool should swing free or burn away the socket or obstruction.</li> </ol>

(Continued on following page.)



10  
(continued...)

SYMPTOM	PROBABLE CAUSE	REQUIRED ACTION
Gauge records no pressure	<ol style="list-style-type: none"> <li>1. Gauge connection is loose</li> <li>2. Bad gauge</li> <li>3. Pump will not build pressure</li> <li>4. Tool seals are blown</li> </ol>	<ol style="list-style-type: none"> <li>1. Tighten coupling.</li> <li>2. Replace gauge</li> <li>3. See cylinder pressure will not build pressure-above</li> <li>4. Replace defective seals. (Call for service)</li> </ol>
Pump will not build pressure	<ol style="list-style-type: none"> <li>1. Air or electric supply is low</li> <li>2. Defective relief or regulator valve</li> <li>3. Low oil or clogged filter</li> <li>4. Internal leak in oil line from external relief valve to pump body.</li> <li>5. Worn sub-plate</li> </ol>	<ol style="list-style-type: none"> <li>1. Check air pressure or voltage.</li> <li>2. Replace valve. (Call for service)</li> <li>3. Fill reservoir and clean filter.</li> <li>4. Open reservoir, inspect oil line while trying to build pressure - if leaking tighten fittings or replace.</li> <li>5. See cylinder pressure will not build pressure-above</li> </ol>
Motor sluggish and inefficient "sounds sick" slow to build pressure	<ol style="list-style-type: none"> <li>1. Air or electric supply is low</li> <li>2. Clogged filter</li> </ol>	<ol style="list-style-type: none"> <li>1. Check air pressure or voltage.</li> <li>2. Clean or replace filter</li> </ol>
Pump heats up	<ol style="list-style-type: none"> <li>1. Improper use</li> <li>2. Remote control is left in "on" position when pump is not actively in use.</li> </ol>	<ol style="list-style-type: none"> <li>1. Operator is continuing to hold down Pump heats up on the advance stroke after the cylinder has reached end of stroke - this causes a lot of oil to go through a very small hole in relief-valve - causing heat build-up. Have operator release advance stroke after accuracy assurance levers spring forward.</li> <li>2. Turn pump off whenever not actually being used. DO NOT leave pump running when tool is not in use.</li> </ol>
Hose or tool fitting is damaged or leaks	<ol style="list-style-type: none"> <li>1. Broken or melted plastic outer covering</li> <li>2. Frayed Kevlar or steel strands</li> <li>3. Oil leaks through fibers</li> <li>4. Broken fittings</li> </ol>	<ol style="list-style-type: none"> <li>1. If underlying Kevlar or steel is still intact continue operation. Inspect frequently.</li> <li>2. Cut hose in half and discard. Replace hose.</li> <li>3. Cut hose in half and discard. Replace hose.</li> <li>4. Remove old fitting and replace with STEEL high pressure fittings only. After changing fittings, always run test #5 (pg. 34) to insure proper plumbing.</li> </ol>
Electric pump will not run	<ol style="list-style-type: none"> <li>1. Loose electric connections in control box.</li> <li>2. Bad brushes</li> <li>3. Motor burned up</li> </ol>	<ol style="list-style-type: none"> <li>1. Open control box and visually inspect for loose threaded or push-on connectors. Reconnect loose wires. If in doubt check wiring diagram. DANGER- BOX CONTAINS HIGH VOLTAGE- ALWAYS UNPLUG PRIOR TO TOUCHING ANYTHING IN CONTROL BOX.</li> <li>2. Change brushes. (Call for service)</li> <li>3. Replace motor or components whichever is necessary. (Call for service)</li> </ol>

(Continued on following page.)

## Tests

### Test #1

Attach hoses to pump and tool in the normal manner. Press the advance button and hold it down. If the pump pressure builds and the hoses “flex” but the tool still refuses to cycle, the problem is most likely a loose or defective coupling connection. To find out where the bad coupling is, remove the tool from the hoses and marry the loose ends together and cycle the pump. If the gauge pressure reads no more than 500 PSI (103 BAR), then the bad fitting is on the tool. A significantly greater pressure indicates that the problem is in either the pump or a hose fitting.

### Test #2

Place a welding rod or thin screwdriver in the opening of either side of the solenoid. Press and then release the advance button. Repeat this process on the opposite side of the solenoid. You should feel the solenoids moving back and forth. If either side is “dead” the solenoid is bad and needs to be replaced. Note: if in an urgent situation, the tool may be cycled manually by pushing the solenoids back and forth through these access holes.

### Test #3

Remove tool from hoses. Cycle pump. If pump fails to build pressure, the problem is with the pump. If it does build pressure, the problem is with hydraulic blow-by in the tool.

### Test #4

Connect tool, pump, and hoses together normally and turn pump “on”. As oil leaks from the small port under the uni-swivel, use a proper size Allen wrench and slowly tighten (clockwise) the set screw positioned between the couplings on the uni-swivel. Continue to tighten until the flow stops plus a quarter turn.

### Test #5

THIS TEST SHOULD BE RUN PRIOR TO EVERY USE OF A HYTORC TOOL

Connect the tool, pump, and hoses together as normal. Cycle the pump several times. Cycle the system once more and observe the sequence of operation. As you depress the advance button, the tool drive should turn about 24 degrees and you should hear an audible “click”. On square drive tools, you will also notice that the accuracy assurance levers will move to the rear of the tool and spring forward. At this point, release the advance button. You should see no further movement and after a moment you will hear another audible “click”. This is how the tools are designed to operate. If you observe any other sequence of operation, the system is out of order and cannot deliver more than 10% of its designed capacity, Take immediate corrective action. For reference, tools and pumps are designed from the factory plumbed as follows. This ensures that the tool, pump and ONE hose cannot possibly be connected up incorrectly.

(Continued on following page.)

**11***(continued...)*

<b>Tool</b>	Advance Side - Male Retract Side - Female
<b>Hose</b>	Advance Side - Female to Female Retract Side - Male to Male
<b>Pump</b>	Advance Side - Male Retract Side - Female

Note that connecting two (or any EVEN number) of hoses together creates "one" hose which is plumbed backwards! Male to Female and Female to Male. This will cause the system to operate backwards per Test #5 above. If your hose isn't long enough, connect 3 hoses together, move your pump or call HYTORC for a longer hose assembly.

# 12 XLT dimensional data - Imperial

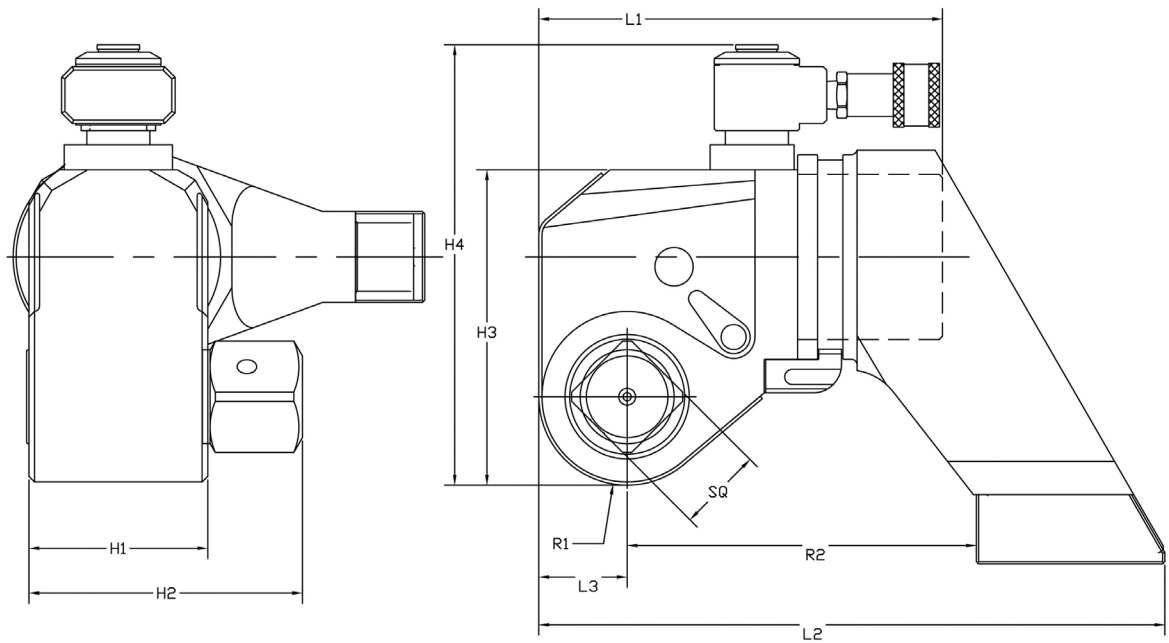

	Inches						Lbs.		Ft.-Lbs.	
	L1	L2	H1	H2	H3	H4	R1	R2	Weight*	Max Torque
HY-.5XLT	3.00	4.91	1.32	1.88	3.00	4.25	0.65	2.57	1.85	397
HY-8XLT	7.70	12.57	3.57	5.09	6.50	8.50	1.76	6.96	24.95	8,000
HY-25XLT	11.80	18.52	5.25	7.48	9.60	11.50	2.60	10.25	68.5	25,890
HY-50XLT	15.50	22.99	6.57	9.36	11.00	12.80	3.25	12.82	124	52,500

	HY-.5XLT	HY-1XLT	HY-3XLT	HY-5XLT	HY-5XLT	HY-10XLT	HY-20XLT	HY-25XLT	HY-50XLT
Square Drive	½"	¾"	1"	1-½"	1-½"	1-½"	2-½"	2-½"	2-½"
Min. Torque (ft.-lbs.)	55	200	480	835	1,200	1,755	2,960	3,960	7,875
Max. Torque (ft.-lbs.)	397	1,340	3,230	5,590	8,000	11,520	19,760	25,890	52,500
Accuracy	± 3%	± 3%	± 3%	± 3%	± 3%	± 3%	± 3%	± 3%	± 3%
Swivel 360° x 180°	STANDARD								

\*The weight listed is for the complete ready-to-use HYTORC tool with reaction arm.

12  
(continued...)

XLT dimensional data - Metric

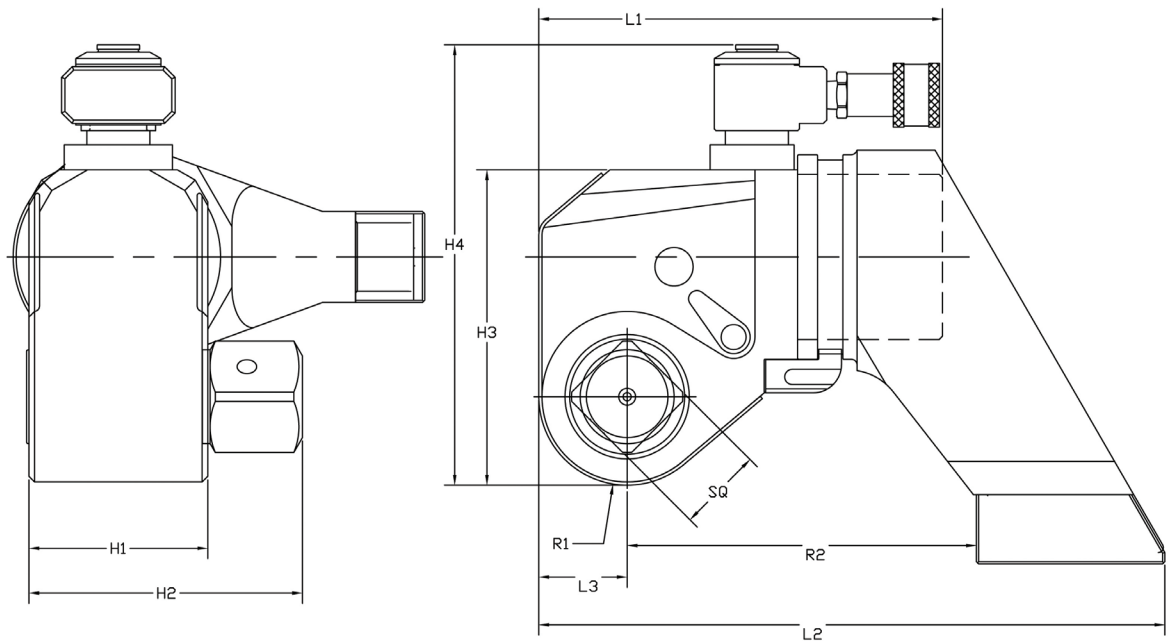

	Millimeters						kg		Nm	
	L1	L2	H1	H2	H3	H4	R1	R2	Weight*	Max Torque
HY-.5XLT	76.20	124.71	33.53	47.75	76.20	107.95	16.51	65.28	0.84	538
HY-8XLT	195.58	319.28	90.68	129.29	165.10	215.90	44.70	176.78	11.34	10,846
HY-25XLT	299.72	470.41	133.35	189.99	243.84	292.10	66.04	260.35	31.14	35,102
HY-50XLT	393.70	583.95	166.88	237.74	279.40	325.12	82.55	325.63	56.36	71,180

	HY-.5XLT	HY-1XLT	HY-3XLT	HY-5XLT	HY-5XLT	HY-10XLT	HY-20XLT	HY-25XLT	HY-50XLT
Square Drive	½"	¾"	1"	1-½"	1-½"	1-½"	2-½"	2-½"	2-½"
Min. Torque (Nm)	81	273	657	1,137	1,627	2,379	4,019	5,265	10,677
Max. Torque (Nm)	538	1,817	4,379	7,579	10,846	15,617	26,791	35,102	71,180
Accuracy	± 3%	± 3%	± 3%	± 3%	± 3%	± 3%	± 3%	± 3%	± 3%
Swivel 360° x 180°	STANDARD								
Uni-Body Housing	TITAL399								
Click-On Reaction Arm	TITAL300, Vertical, 360°, Tension absorbing								

\*The weight listed is for the complete ready-to-use HYTORC tool with reaction arm.

# 13 MXT dimensional data - Imperial

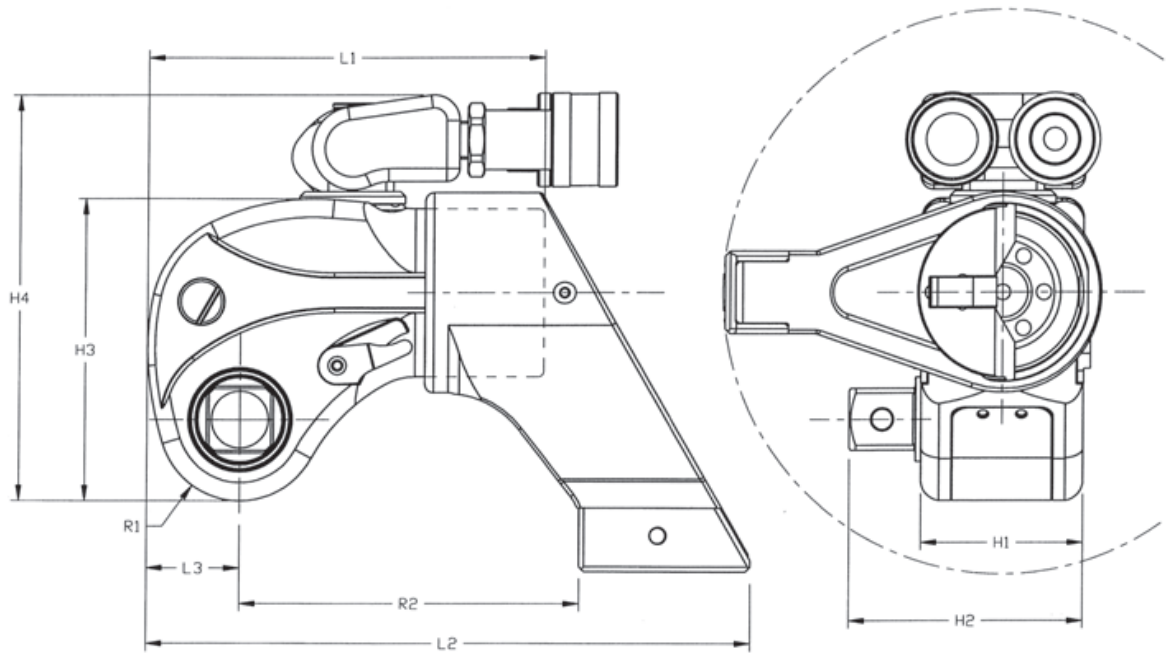

	Inches									Lbs.
	L1	L2	L3	H1	H2	H3	H4	R1	R2	Weight*
MXT-.7	3.96	5.98	0.93	1.62	2.53	3.00	4.25	0.81	3.32	2.7
MXT-1	4.88	7.33	1.13	1.97	2.85	3.66	4.9	0.98	4.12	3.95
MXT-3	6.34	9.6	1.51	2.63	3.81	4.88	6.12	1.31	5.32	8.3
MXT-5	7.61	11.52	1.81	3.16	4.92	5.85	7.22	1.57	6.4	14.2
MXT-10	9.51	14.38	2.26	3.95	5.62	7.32	8.80	1.96	7.97	24.8
MXT-15	10.55	15.29	2.51	4.38	7.0	8.06	9.67	2.18	8.63	36
MXT-20	11.41	17.27	2.71	4.73	7.1	8.78	10.24	2.36	9.58	43.4
MXT-35	14.03	21.23	3.33	5.82	8.32	10.79	12.36	2.90	11.74	77.45

	MXT-.7	MXT-1	MXT-3	MXT-5	MXT-10	MXT-15	MXT-20	MXT-35
Square Drive	3/4"	3/4"	1"	1-1/2"	1-1/2"	2-1/2"	2-1/2"	2-1/2"
Min. Torque (ft.-lbs..)	123	201	484	838	1,728	2,388	2,964	5,564
Max. Torque (ft.-lbs..)	822	1,340	3,230	5,589	11,519	15,920	19,757	37,095
Accuracy	± 3%	± 3%	± 3%	± 3%	± 3%	± 3%	± 3%	± 3%
Swivel 360° x 180°	STANDARD							
Uni-Body Housing	TITAL399							
Click-On Reaction Arm	TITAL300, Vertical, 360°, Tension absorbing							

\*The weight listed is for the complete ready-to-use HYTORC tool with reaction arm.

## 13

(continued...)

## MXT dimensional data - Metric

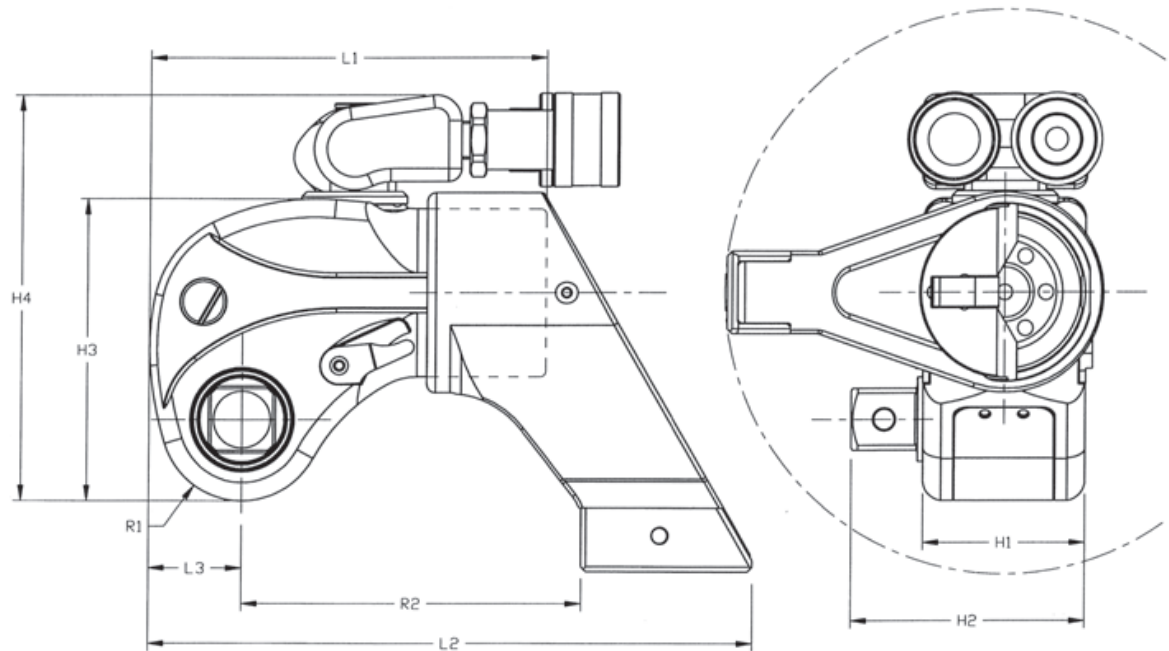

	Millimeters									kg
	L1	L2	L3	H1	H2	H3	H4	R1	R2	Weight*
MXT-.7	100.6	151.9	23.6	41.2	64.3	76.2	108.0	20.6	84.3	1.2
MXT-1	123.9	186.2	28.7	50.0	72.4	93.0	124.5	25.0	104.7	1.8
MXT-3	161.0	243.8	38.4	66.8	96.8	124.0	155.5	33.3	135.1	3.8
MXT-5	193.3	292.6	46.0	80.3	125.0	148.6	183.4	39.9	162.6	6.5
MXT-10	241.6	365.3	57.4	100.3	142.8	185.9	223.5	49.8	202.4	11.3
MXT-15	268.1	388.3	63.6	111.1	177.8	204.7	245.6	55.4	219.2	16.4
MXT-20	289.8	438.7	68.8	120.1	180.3	223.0	260.1	59.9	243.3	19.7
MXT-35	356.3	539.2	84.6	147.8	211.3	274.1	313.9	73.7	298.2	35.2

	MXT-.7	MXT-1	MXT-3	MXT-5	MXT-10	MXT-15	MXT-20	MXT-35
Square Drive	3/4"	3/4"	1"	1-1/2"	1-1/2"	2-1/2"	2-1/2"	2-1/2"
Min. Torque (Nm)	167	273	657	1,137	2,343	3,238	4,018	7,544
Max. Torque (Nm)	1,114	1,817	4,379	7,578	15,617	21,584	26,787	50,293
Accuracy	± 3%	± 3%	± 3%	± 3%	± 3%	± 3%	± 3%	± 3%
Swivel 360° x 180°	STANDARD							
Uni-Body Housing	TITAL399							
Click-On Reaction Arm	TITAL300, Vertical, 360°, Tension absorbing							

\*The weight listed is for the complete ready-to-use HYTORC tool with reaction arm.

# 14 MXT-SA dimensional data - Imperial

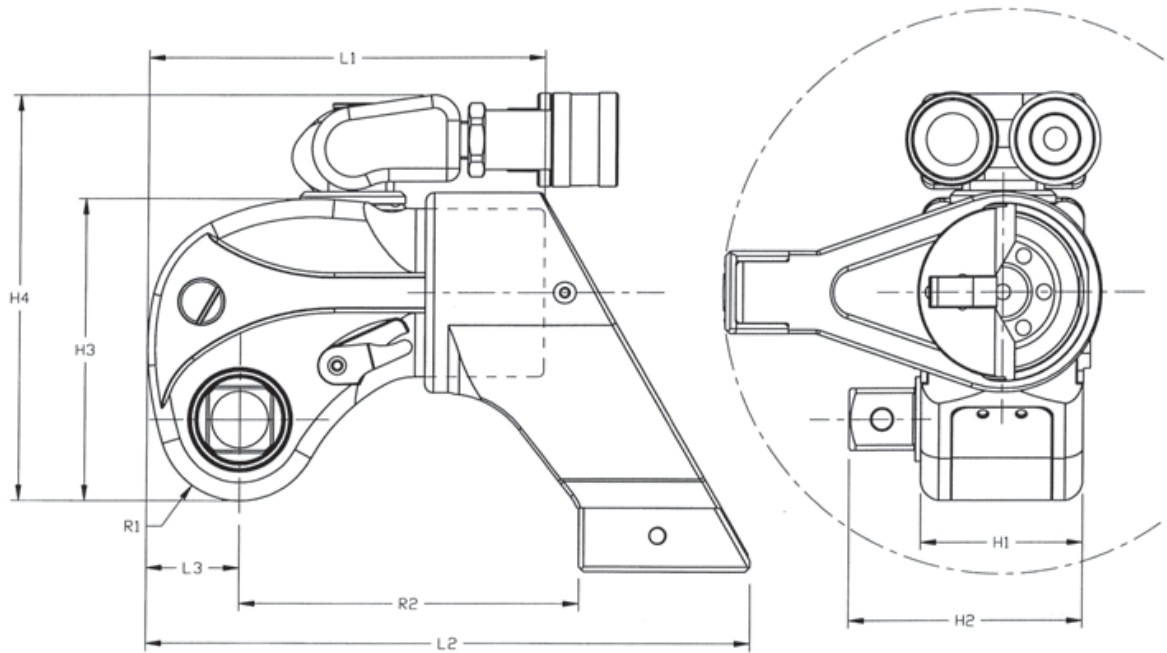

	Inches									Lbs.	Ft.-Lbs.
	L1	L2	L3	H1	H2	H3	H4	R1	R2	Weight*	Max Torque
MXT-.7-SA	3.96	5.95	0.93	1.62	2.53	3.00	4.25	0.81	3.32	3.3	397
MXT-1-SA	4.88	7.33	1.13	1.97	2.85	3.66	4.9	0.98	4.12	4.45	1,340
MXT-3-SA	6.34	9.6	1.51	2.63	3.81	4.88	6.12	1.31	5.32	9.95	3,230
MXT-5-SA	7.61	11.52	1.81	3.16	4.92	5.85	7.22	1.57	6.4	16.75	5,590
MXT-10-SA	9.51	14.38	2.26	3.95	5.62	7.32	8.80	1.96	7.97	24.95	8,000

	MXT-.7-SA	MXT-1-SA	MXT-3-SA	MXT-5-SA	MXT-10-SA
Square Drive	¾"	1"	1"	1-½"	1-½"
Min. Torque (ft.-lbs.)	60	201	485	839	1,200
Max. Torque (ft.-lbs.)	397	1,340	3,230	5,590	8,000
Accuracy	± 3%	± 3%	± 3%	± 3%	± 3%
Swivel 360° x 180°	STANDARD				
Uni-Body Housing	TITAL399				
Click-On Reaction Arm	TITAL300, Vertical, 360°, Tension absorbing				

\*The weight listed is for the complete ready-to-use HYTORC tool with reaction arm.



## 14

(continued...)

## MXT-SA dimensional data - Metric

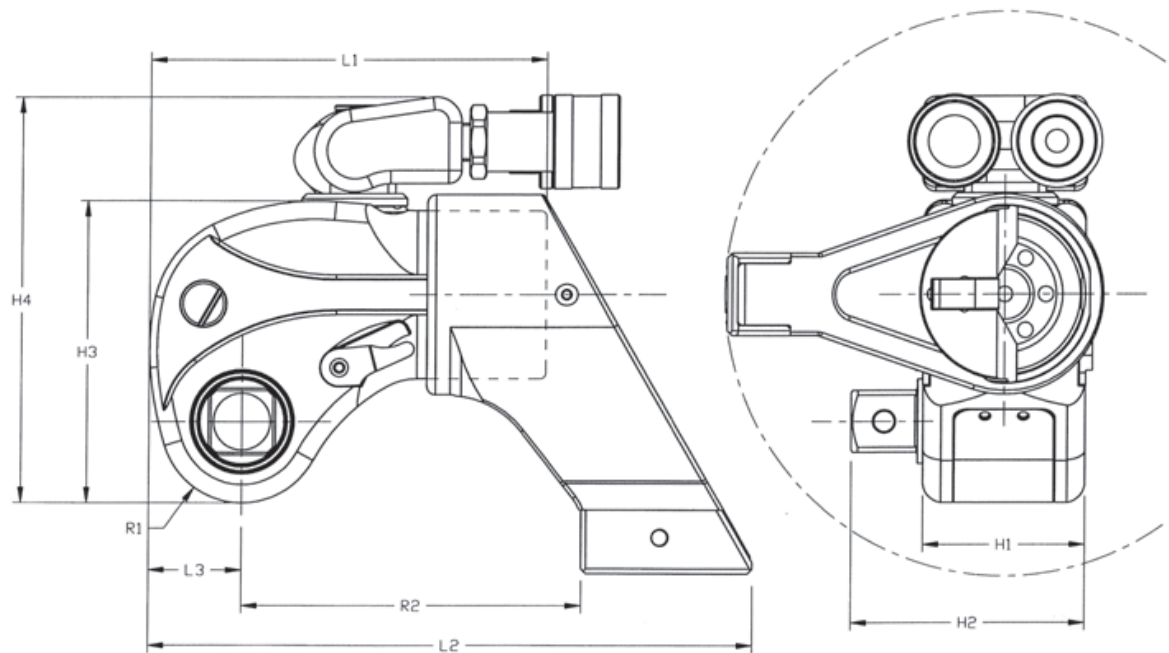

	Millimeters								kg	Nm	
	L1	L2	L3	H1	H2	H3	H4	R1	R2	Weight*	Max Torque
MXT-.7-SA	100.6	151.0	23.5	41.1	64.3	76.2	108.0	20.6	84.3	1.5	538
MXT-1-SA	123.9	186.2	28.7	50.0	72.4	93.0	124.5	25.0	104.6	2.0	1,817
MXT-3-SA	161.0	243.8	38.4	66.8	96.8	123.9	155.4	33.3	135.1	4.5	4,379
MXT-5-SA	193.3	292.6	46.0	80.3	125.0	148.6	183.4	39.9	162.6	7.6	7,579
MXT-10-SA	241.6	365.3	57.4	100.3	142.7	185.9	223.5	49.8	202.4	11.3	10,846

	MXT-.7-SA	MXT-1-SA	MXT-3-SA	MXT-5-SA	MXT-10-SA
Square Drive	¾"	1"	1"	1-½"	1-½"
Min. Torque (Nm)	81	273	657	1,137	1,627
Max. Torque (Nm)	538	1,817	4,379	7,579	10,846
Accuracy	± 3%	± 3%	± 3%	± 3%	± 3%
Swivel 360° x 180°	STANDARD				
Uni-Body Housing	TITAL399				
Click-On Reaction Arm	TITAL300, Vertical, 360°, Tension absorbing				

\*The weight listed is for the complete ready-to-use HYTORC tool with reaction arm.

# 15 Bolt / Torque / HYTORC

The data below is based on bolts lubricated to manufacturer's specifications. Due to variations in friction, we recommend in extreme cases to check with the bolt manufacturer, as this chart represents a guideline only.

SAE1 SEA2 30,000 PSI	ASTM B7 Bolt	B-7 A/F Heavy Hex Nut	ASTM 354 B8 60,000 PSI	FT.-LBS.	RECOMMENDED MXT MODELS	
					MXT SERIES MAKE-UP ONLY	MXT SERIES MAKE-UP/BREAK-OUT
1"	7/8"	1-7/16"	7/8"	300	HY-.5XLT/MXT .7	HY-.5XLT/MXT .7
1-1/8"	1"	1-5/8"		425	HY-1 MXT	HY-1XLT
			1"	500	HY-1 MXT	HY-1XLT
1-1/4"				600	HY-1 MXT	HY-1XLT
1-3/8"	1-1/8"	1-13/16"	1-1/8"	700	HY-1 MXT	HY-1XLT
	1-1/4"	2"		800	HY-1 MXT	HY-1XLT
1-1/2"				900	HY-1 MXT	HY-1XLT
			1-1/4"	1,000	HY-1 MXT	HY-3XLT
1-5/8"	1-3/8"	2-13/16"		1,250	HY-1 MXT	HY-3XLT
			1-3/8"	1,350	HY-3MXT	HY-3XLT
	1-1/2"	2-3/8"		1,500	HY-3MXT	HY-3XLT
1-3/4"				1,600	HY-3MXT	HY-3XLT
1-7/8"				1,800	HY-3MXT	HY-5XLT
	1-5/8"	2-9/16"		2,000	HY-3MXT	HY-5XLT
2"			1-5/8"	2,200	HY-3MXT	HY-5XLT
	1-3/4"	2-3/4"		2,600	HY-5MXT	HY-5XLT
2-1/4"			1-3/4"	3,000	HY-5MXT	HY-5XLT
	1-7/8"	2-15/16"		3,700	HY-5MXT	HY-8XLT
2-1/2"	2"	3-1/8"	1-7/8"	4,000	HY-5MXT	HY-8XLT
			2"	4,400	HY-8MXT	HY-10XLT
2-3/4"				5,100	HY-8MXT	HY-10XLT
	2-1/4"	3-1/2"	2-1/4"	6,000	HY-10MXT	HY-10XLT
3"				7,000	HY-10MXT	HY-20XLT
	2-1/2"	3-7/8"		8,000	HY-10MXT	HY-20XLT
3-1/4"			2-1/2"	9,000	HY-10MXT	HY-20XLT
3-1/2"	2-3/4"	4-1/4"		10,000	HY-20MXT	HY-25XLT
			2-3/4"	11,500	HY-20MXT	HY-25XLT
3-3/4"	3"	4-5/8"		13,000	HY-20MXT	HY-25XLT
4"				14,500	HY-25MXT	HY-25XLT
			3"	15,500	HY-25MXT	HY-25XLT
	3-1/4"	5"		16,500	HY-25MXT	HY-25XLT
4-1/4"			3-1/4"	19,500	HY-25MXT	HY-50XLT
	3-1/2"	5-3/8"		20,500	HY-25MXT	HY-50XLT
4-1/2"				21,500	HY-25MXT	HY-50XLT
			3-1/2"	24,500	HY-50XLT	HY-50XLT
4-3/4"	3-3/4"	5-3/4"		25,500	HY-50XLT	HY-50XLT
6-1/2"	4-1/4"			29,500	HY-50XLT	HY-50XLT
5"	4"	6-1/8"	3-3/4"	30,500	HY-50XLT	HY-50XLT
	4-1/2"	6-7/8"		35,500	HY-50XLT	
			4"	37,000	HY-50XLT	
	4-3/4"	7-1/4"		41,000	HY-50XLT	
			4-1/4"	44,000	HY-50XLT	
	5"	7-5/8"		47,500		
			4-1/2"	52,000		
			4-3/4"	61,000		
			5"	71,500		

# 16 Square / Allen drive working torque

DRIVE SIZE: The square or hex drive of each HYTORC is limited in its maximum output by its material and its engagement area. Since your HYTORC uses specially suited alloy steel for its drive members, the following maximum torque output can be achieved without drive failure, provided the reaction member abuts close to the same plane as the nut to be turned.

DRIVE SIZE	MAXIMUM WORKING TORQUE	PROBABLE FAILURE
1/2" Allen	350 ft.-lbs.	380 ft.-lbs.
1/2" Square	385 ft.-lbs.	425 ft.-lbs.
5/8" Allen	685 ft.-lbs.	750 ft.-lbs.
3/4" Allen	1,185 ft.-lbs.	1,300 ft.-lbs.
3/4" Square	1,390 ft.-lbs.	1,485 ft.-lbs.
7/8" Allen	1,880 ft.-lbs.	2,065 ft.-lbs.
1" Allen	2,810 ft.-lbs.	3,100 ft.-lbs.
1" Square	3,230 ft.-lbs.	3,400 ft.-lbs.
1-1/8" Allen	4,000 ft.-lbs.	4,400 ft.-lbs.
1-1/4" Allen	5,500 ft.-lbs.	6,100 ft.-lbs.
1-3/8" Allen	7,300 ft.-lbs.	8,000 ft.-lbs.
1-1/2" Allen	9,500 ft.-lbs.	10,400 ft.-lbs.
1-1/2" Square	11,520 ft.-lbs.	12,475 ft.-lbs.
1-5/8" Allen	12,000 ft.-lbs.	13,200 ft.-lbs.
1-3/4" Allen	15,000 ft.-lbs.	16,500 ft.-lbs.
1-7/8" Allen	18,500 ft.-lbs.	20,300 ft.-lbs.
2" Allen	22,500 ft.-lbs.	24,700 ft.-lbs.
2-1/4" Allen	32,000 ft.-lbs.	35,100 ft.-lbs.
2-1/2" Allen	44,000 ft.-lbs.	48,200 ft.-lbs.
2-1/2" Square	52,500 ft.-lbs.	63,625 ft.-lbs.

If the reaction arm cannot abut on the same plane as the nut to be turned. Less torque should be applied as the additional side load has to be taken into consideration.

When torque requirements are close or more than the values listed above, use HYTORC's Socket Hex - Drive with replaceable Hex Insert Bits.

## 17 Customer service policy

With the purchase of a HYTORC bolting system (past, present, and future) you have obtained the latest technology and lifetime, worldwide local support.

### **Free services:**

- FREE User Safety Training upon Receipt of Merchandise
- FREE Semi-Annual User Safety Training on Request
- FREE Annual Safety Seminar on Appointment
- FREE Loaner Tools in case of Product Failure within 24 Hours
- FREE Torque/Tension Consultation/Seminar
- FREE Half Day, First Use Supervision
- FREE Annual Product Inspection on Request
- FREE Product Demonstrations
- FREE 12 Month No-Questions-Asked Warranty
- FREE 5 Year Tool Housing Warranty
- FREE Upgrades during the Lifetime of the Tool to Enhance Safety, Durability, and Function  
*(Above services are NOT subject to travel expense charges)*

### **Repairs:**

- All Repairs are Guaranteed for 6 Months
- Repairs are Subject to Labor and Part Cost, as Outlined in the Official HYTORC Price List
- All Warranty Repairs are FREE of All Charges Including Return-Freight
- All Repairs Will be Tested and Calibrated to Ensure the Highest Quality Repairs



## OPTIMIZE YOUR BOLTING

Since 1968, HYTORC has been the worldwide leader in industrial bolting systems & solutions. Supplying and supporting Industrial bolting is our complete and total focus.

HYTORC is the only company that can provide you with significant productivity enhancements to your bolting work.

These enhancements provide our customers with tremendous value, giving them the opportunity to receive a return on their investment after the first job together.

Our 50 years of experience in industrial bolting gives us an unsurpassed knowledge and understanding of how to find solutions that are practical and effective for our customers.

# HYTORC

Division UNEX Corporation

333 Route 17N, Mahwah, New Jersey 07430 USA

800-FOR-HYTORC • 201-512-9500 • [info@HYTORC.com](mailto:info@HYTORC.com) • [www.HYTORC.com](http://www.HYTORC.com)