



jGun® DIGITAL Single Speed Pneumatic Torque Tool

The jGun DIGITAL Single Speed from HYTORC is the world's first torque-adjustable pneumatic multiplier with a digital readout and FRL-free operation. Unlike other systems that require a separate filter, regulator and lubrication system between the air line and the tool, the patented design of the jGun DIGITAL Single Speed eliminates the need for this add-on for the highest level of portability and convenience.

DIGITAL READOUT



The jGun DIGITAL Single Speed is the world's first industrial torque multiplier with a digital readout for instant confirmation of selected torque. No more pressure-to-torque conversions or calculations. Select between ft-lbs and Nm.

BUILT-IN TORQUE ADJUSTMENT



The jGun DIGITAL Single Speed is the first of its kind with an onboard air regulator for simple torque adjustment with a twist of the connector at the bottom of the handle. Especially convenient when switching from tightening to loosening, giving you the ability to quickly adjust to full power for fast and easy break-out.

INDUSTRIAL-GRADE MOTOR



The new motor featured in the jGun DIGITAL Single Speed is a workhorse designed for heavy industrial use. With maximum power-to-weight ratio and a rugged corrosion-resistant design, this motor eliminates the need for separate air filters and lubrication systems, making the jGun DIGITAL Single Speed the most portable air powered torque gun on the market.

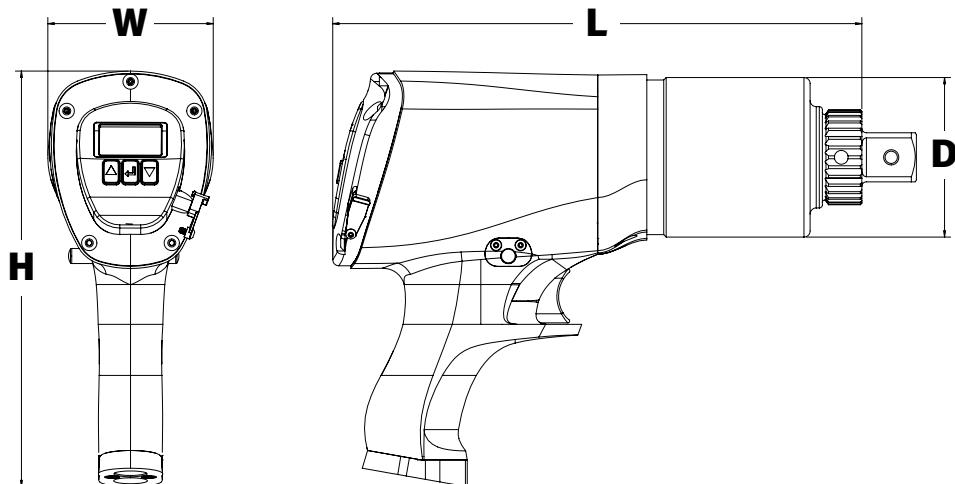

LEGEND: H = HEIGHT W = WIDTH L = LENGTH D = OUTER DIAMETER OF GEARBOX

| MODEL NUMBER | H | W | L | D | SQUARE DRIVE | WEIGHT | TORQUE | | RPM |
|--------------|------|------|-------|------|--------------|--------|--------------|--------------|------|
| IMPERIAL | in. | | | | | lbs. | ft-lbs (Min) | ft-lbs (Max) | |
| JGUN-D.25 | 7.87 | 3.15 | 7.11 | 2.50 | 3/4 | 8.25 | 50 | 250 | 65.0 |
| JGUN-D.5 | 7.87 | 3.15 | 8.11 | 2.58 | 3/4 | 8.85 | 135 | 500 | 24.0 |
| JGUN-D1 | 7.87 | 3.15 | 8.90 | 2.58 | 3/4 | 9.8 | 300 | 1,175 | 6.5 |
| JGUN-D2 | 8.41 | 3.37 | 10.79 | 3.25 | 1 | 16.5 | 540 | 2,090 | 5.5 |
| JGUN-D3 | 8.41 | 3.37 | 11.46 | 3.25 | 1 | 17.7 | 856 | 3,180 | 5.0 |
| JGUN-D5 | 8.41 | 3.37 | 12.42 | 4.15 | 1-1/2 | 28.3 | 1,150 | 5,050 | 2.5 |
| JGUN-D6.5 | 8.41 | 3.37 | 12.88 | 3.99 | 1-1/2 | 21.95 | 2,300 | 6,500 | 2.4 |
| JGUN-D8 | 8.41 | 3.37 | 13.48 | 4.56 | 1-1/2 | 38.4 | 2,300 | 7,900 | 1.5 |

| METRIC | mm | | | | in. | kg | Nm (Min) | Nm (Max) | RPM |
|-----------|-----|----|-----|-----|-------|-------|----------|----------|------|
| JGUN-D.25 | 200 | 80 | 181 | 64 | 3/4 | 3.75 | 81 | 339 | 65.0 |
| JGUN-D.5 | 200 | 80 | 206 | 66 | 3/4 | 4.02 | 251 | 678 | 24.0 |
| JGUN-D1 | 200 | 80 | 226 | 66 | 3/4 | 4.45 | 475 | 1592 | 6.5 |
| JGUN-D2 | 214 | 86 | 274 | 83 | 1 | 7.50 | 780 | 2832 | 5.5 |
| JGUN-D3 | 214 | 86 | 291 | 83 | 1 | 8.05 | 1161 | 4309 | 5.0 |
| JGUN-D5 | 214 | 86 | 315 | 105 | 1-1/2 | 12.86 | 1891 | 6843 | 2.5 |
| JGUN-D6.5 | 214 | 86 | 327 | 101 | 1-1/2 | 9.95 | 3118 | 8813 | 2.4 |
| JGUN-D8 | 214 | 86 | 342 | 116 | 1-1/2 | 17.45 | 3118 | 10705 | 1.5 |

The World's Most Trusted Industrial Bolting Systems

HYTORC owns all content, copyrights, trademarks and patents in this document. © 2023 HYTORC. Any unauthorized use or distribution of any material from this document is strictly prohibited.



Headquarters:
333 Route 17 N., Mahwah, NJ 07430
+1-201-512-9500

Email:
info@hytorc.com

Phone:
1-800-FOR-HYTORC

Online:
hytorc.com