

HYTORC

The World's Most Trusted Industrial Bolting Systems



TEST REPORT

Validation of HYTORC J-Washer Reaction Washer
According to DIN 25201 "Vibration Test"

333 Route 17 N.
Mahwah, NJ 07430
USA

800-FOR-HYTORC
(800-367-4986)
201-512-9500

sales@hytorc.com
hytorc.com

TABLE OF CONTENTS

| | |
|---|----|
| SUMMARY | 1 |
| 1. INTRODUCTION AND BACKGROUND | 1 |
| 2. PRODUCT UNDER TEST - HYTORC J-WASHER | 2 |
| 3. INDEPENDENT TEST LAB AND REPORT | 3 |
| 4. TEST SETUP | 3 |
| 5. TEST PROCEDURE | 4 |
| 6. VIBRATION TEST RESULTS | 6 |
| 7. CONCLUSION | 13 |
| REFERENCES | 14 |
| CHANGELOG | 14 |

NOTICE OF PROPRIETARY RIGHTS: HYTORC Division UNEX Corporation ("HYTORC") is the owner of all content included in this document and all right, title and interest to such content shall remain with HYTORC. COPYRIGHT NOTICE: © 2021 HYTORC. Any unauthorized use or distribution of any material from this document, without HYTORC's written permission, is strictly prohibited. TRADEMARK NOTICE: This document contains numerous registered trademarks and servicemarks of HYTORC in the U.S. and other countries. PATENT NOTICE: Products in this document are covered by numerous registered and/or pending patents in the U.S. and other countries.

SUMMARY

This report describes tests and results for the HYTORC J-Washer performed at an Independent Test Lab (ITL) during 2020. The test program was conducted per requirements in the DIN 25201 Vibration Test procedure also known as the "Junker" Test. The tests evaluated bolt sizes of 1/2-inch, 1-1/2-inch and 1-7/8-inch. All test samples including bolts, nuts and HYTORC J-Washers were supplied by HYTORC. The ITL inspected, lubricated and assembled all samples into the Junker fixture for each test run according to the prescribed test procedure. An initial reference test was conducted for each sample size to determine the required threshold for the vibration test parameters. All samples were then subjected to the transverse vibration test during which the load and relative position of nuts was monitored. The results show that all samples of the fasteners tested with the J-Washer remained tight during the tests and successfully satisfied all Junker test pass criteria.

1. INTRODUCTION AND BACKGROUND

Bolt loosening may occur in heavy industrial applications such as rotating machinery, rolling machinery, transportation, mining, wind towers, cranes, bridges, roads and other applications. In these applications transverse forces acting on the bolted joint become greater than the frictional resistance of the preload and relative motion occurs between mating threads and the fastener bearing surfaces. Bolted joints subjected to repeated transverse movements can completely loosen fasteners causing dangerous conditions.

While many fastener components claim to have anti-loosening properties, it is commonly known that not all perform equally. In order to verify the performance of locking features of various components the industry has developed standardized testing. The standard began in 1969 when Gerhard Junker published his classic paper, "New Criteria for Self-Loosening of Fasteners Under Vibration." [1] The Junker Test, as it became known, was later standardized in the original DIN 65151 [2], which tested the self-loosening behavior of fasteners under transverse loading conditions. In 2010 the industry published DIN 25201 [3] which builds on the original DIN 65151 but takes things much further by defining exactly how to conduct vibration testing of fasteners [4].

The DIN 25201 test is completed using a Junker Test fixture with test parameters that match operating conditions of the fastener as closely as possible. The DIN 25201 procedure also includes a 'reference test' procedure to discover the effective displacement at which the bolt starts to self-loosen, so that the performance of the securing element, or locking mechanism, can be effectively tested [4]. The DIN 25201 passing criteria considers the locking mechanism to be 'adequate' if there is 80% or more of the pre-stressing force, from when the test started, remaining after 2,000 load cycles. Based on the plot of the pre-stressing force against the number of load cycles, the pre-stressing force curve must show that it is unlikely that the fastener would have failed if the test continued beyond 2,000 cycles.

2. PRODUCT UNDER TEST- HYTORC J-WASHER

The HYTORC J-Washer shown in Figure 1 (below) is a through-hardened steel washer designed for use in heavy duty industrial bolting applications where vibration loosening can be an issue. This washer is a slight variation of the standard HYTORC washer which is manufactured to meet specifications of ASTM F3394/F3394M "Standard Specification for Hardened Steel Backup and Reaction Washers." [5]

The J-Washer beveled side is exactly the same as the ASTM F3394 Reaction Washer. The knurls located on the beveled side when installed face the plate or flange of the bolted joint. The knurls provide sufficient friction to counter the rotational reaction forces when the nut is tightened with torque. The HYTORC Reaction Washer also contains an outer edge consisting of lobes that engage with the torque tool reaction driver to eliminate the need for reaction arms and significantly improve safety.

The J-Washer flat side integrates an additional knurl ridge not present in the standard Reaction Washer. This additional knurl ridge engages the nut and acts as a locking feature to keep the nut from turning once tightened. This locking feature prevents the loosening of pre-loaded fasteners during the vibration test.

The correct orientation of the J-Washer beveled side and flat side is a critical factor in the performance of the product during test and in actual applications. All tests described in this report were assembled according to the manufacturers recommended installation procedure with correct orientation.

Figure 1 - Product Under Test - HYTORC J-Washer

Beveled Side



Flat Side



3. INDEPENDENT TEST LAB AND REPORT

The tests described in this document were conducted at an Independent Test Lab (ITL) to ensure objective and neutral test setup and results. The ITL is independently accredited to ISO 17025 standards and is a member of American Association for Laboratory Accreditation. The test lab controlled the exact physical parameters of the test setup including details such as fastener assembly, lubrication and exact sample grade quality and size for tests performed. The lab was responsible for setup of the reference tests and determining the prestress levels. The lab conducted all vibration tests and recorded all data including monitoring results. All data reproduced in this report was provided by the test lab directly from their data acquisition system.

4. TEST SETUP

The J-Washer was tested using a standard DIN 25201 fixture to produce the transverse vibration that can loosen fasteners. A schematic of the test setup is shown in Figure 2. The fastener assembly includes the bolt, J-Washer and nut which are installed in the fixture such that the head of the bolt is fixed in place. The bolt is inserted into the fixture and the J-Washer is installed with beveled side against the plate. The threads are lubricated and the nut is tightened against the J-Washer flat side. The bolt is tightened to the required load and the fasteners are marked with a reference line through the bolt, nut, washer and plate. During the test the machine creates relative motion between the top plate and bottom plate simulating the transverse vibration. The load is monitored during the course of the test with a computer data acquisition system and a video camera monitors the marks on the top plate, bolt, nut and washer.

Figure 2 - DIN25201 "Junker Test" Test Setup

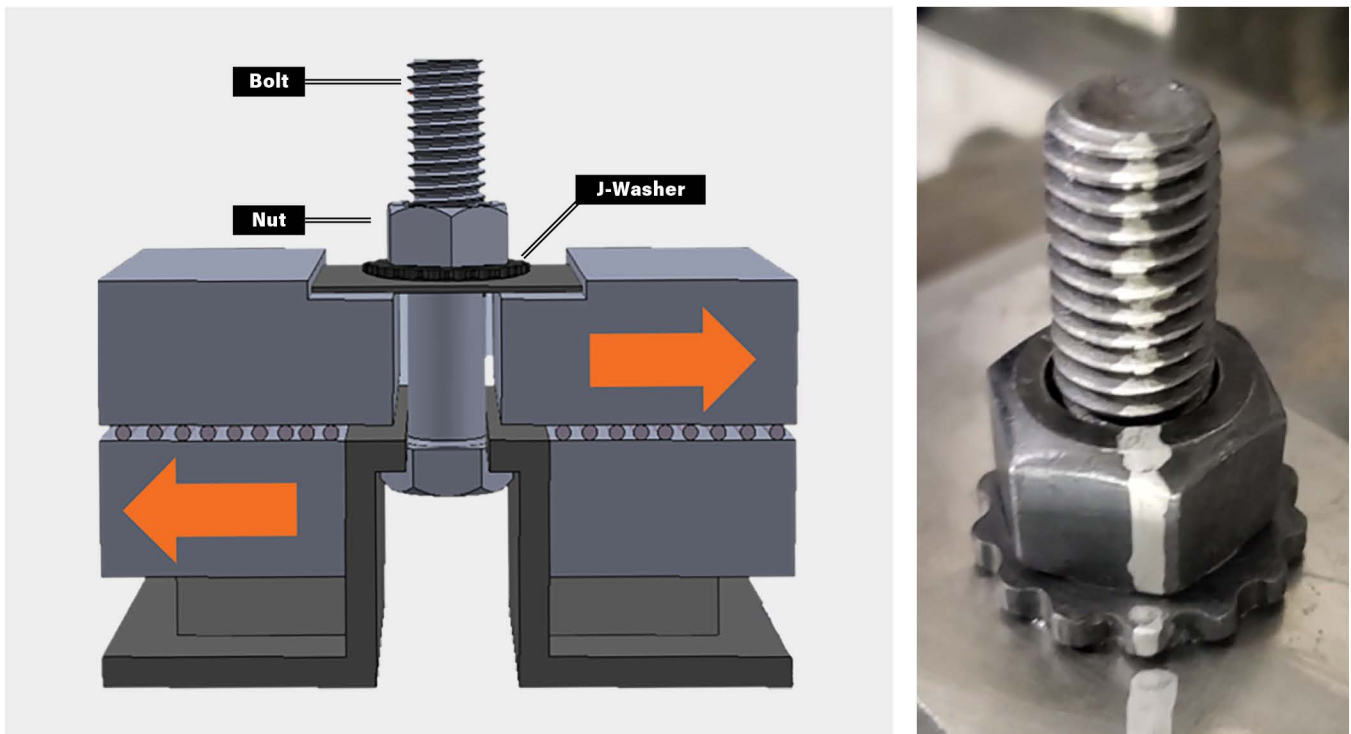

5. TEST PROCEDURE

All sample bolts, nuts, flat washers and J-Washers were provided by HYTORC. The Laboratory received, inspected and prepared the samples. A new sample is used for each test run.

FIGURE 3

Test hardware for
1/2-inch (13 mm) size fasteners



FIGURE 4

Test hardware for
1-1/2-inch (38 mm) size fasteners



FIGURE 5

Test hardware for
1-7/8-inch (48 mm) size fasteners



5. TEST PROCEDURE (CONT'D.)

Reference tests were conducted by testing fastener assemblies with a general Flat Washer (without the J-Washer) to determine the effective displacement at which the bolted joint fully loses preload. Test setup was done according to the DIN 25201 setup configuration. Once the effective displacement has been discovered by the initial reference test, three subsequent reference tests were performed with new bolts to ensure that the effective displacement is correct. Test parameters for the Reference Test are shown in Table 1 Column A.

For the actual vibration test runs, the J-Washer is used instead of the Flat Washer following the standard DIN 25201 setup. The clamping force is monitored during each test run. If the residual load is maintained at greater than eighty percent of the original load, then the fastener assembly with the J-Washer is deemed to have passed. A new sample is used with each test run and the test is repeated twelve times for each size fastener. The ITL data acquisition system provides real-time data collection of both the load [lbf] and displacement [in] applied to the bolting system. The data was exported in .CSV format and plotted to the charts in this report

Table 1 - Test Parameters

| PARAMETER | A - REFERENCE TESTS | B - VIBRATION TEST RUNS |
|-----------------------------------|--|--|
| Bolt Nominal Size (inch) | 1/2" / 13 mm 1-1/2" / 38 mm 1-7/8" / 48 mm | 1/2" / 13 mm 1-1/2" / 38 mm 1-7/8" / 48 mm |
| Bolt Grade | B7 | B7 |
| Nuts Grade | 2H | 2H |
| Washer | F436 Flat Washer | HYTORC J-Washer |
| Clamp Length Ratio | 2:1 4:1 2.8:1 | 2:1 4:1 2.8:1 |
| Number of Tests | 3 Repetitions Each Size | 12 Repetitions Each Size |
| Lubricant | Molycote | Molycote |
| Test Temperature (°F/°C) | 75/23 | 75/23 |
| Test Frequency (Hz) | 12.5 | 12.5 |
| Test Displacement (in./mm) | ±0.018 / ±0/45 (1/2" / 13 mm) ±0.082 / ±2.1 (1-1/2" / 38 mm) ±0.13 / ±3.3 (1-7/8" / 48 mm) | ±0.018 / ±0/45 (1/2" / 13 mm) ±0.082 / ±2.1 (1-1/2" / 38 mm) ±0.13 / ±3.3 (1-7/8" / 48 mm) |
| Clamping Load (lbf) | 50% of Yield | 50% of Yield |
| Cycles Tested | 2,000 | 2,000 |
| Surface Coating | None | Black Oxide |

6. VIBRATION TEST RESULTS

The vibration tests were run 12 times of for each bolt size. Every test was performed with a new fastener assembly including a new bolt, nut and J-Washer. The original preload clamping force was 50% of the yield strength of the bolt. The 12 test results for each size bolt are averaged and plotted in the graph over the duration of the test. For the metric plots a conversion from the imperial results has performed to convert pounds to kilonewtons.

1/2-inch (13 mm) J-Washer Results

The test result summary for the 1/2 inch J-Washer is shown in Table 2. The 1/2 inch J-Washer maintained an average clamping force of ninety-one percent (91%) of the original load after 2,000 cycles. When monitored over 2,000 cycles the clamping force did not fall below 80% of the original load. The bolt load was monitored throughout the test and is plotted in Figure 6 for imperial and Figure 7 for metric. The relative percent load throughout the test is plotted in Figure 8. Based on the trajectory of the curves at the end of the test it is unlikely that the bolt load would be loosened even if the test was continued beyond the 2,000 cycles.

Table 2 - Vibration Test Result Summary for 1/2" J-Washer

| PARAMETER | VALUE |
|-------------------------------------|----------------------|
| Nominal Bolt Size (imperial/metric) | 0.5" / 13 mm |
| Part Number | JRW-008 |
| Number of Samples Tested | 12 |
| Average Load Initial | 3,868 lbf / 17,21 KN |
| Average Load at Cycle 2,000 | 3,509 lbf / 15,62 KN |
| Average Percent Load at Cycle 2,000 | 91% |

6. VIBRATION TEST RESULTS (CONT'D.)

Figure 6 - Vibration Test Results - Clamping Force for 1/2" Fastener with J-Washer (Imperial)

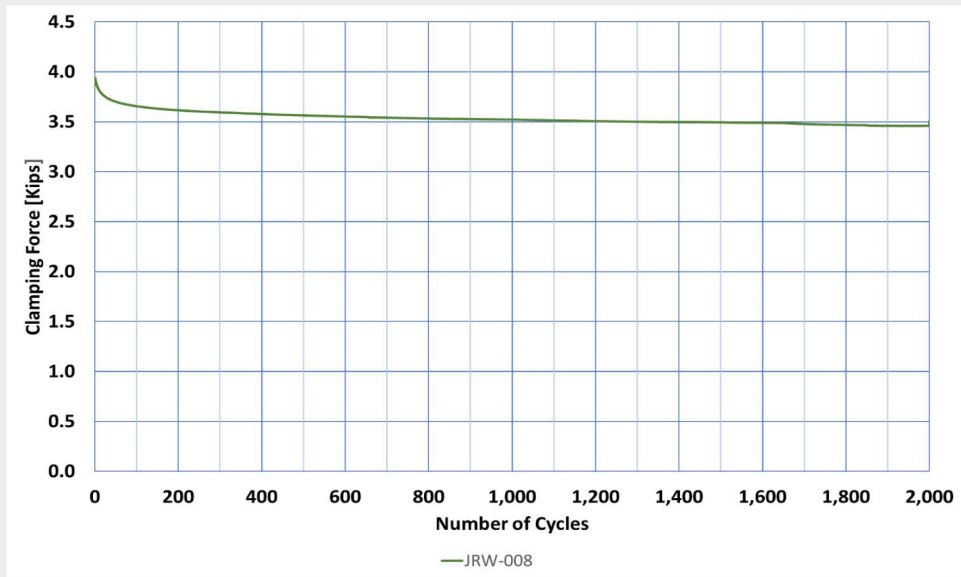
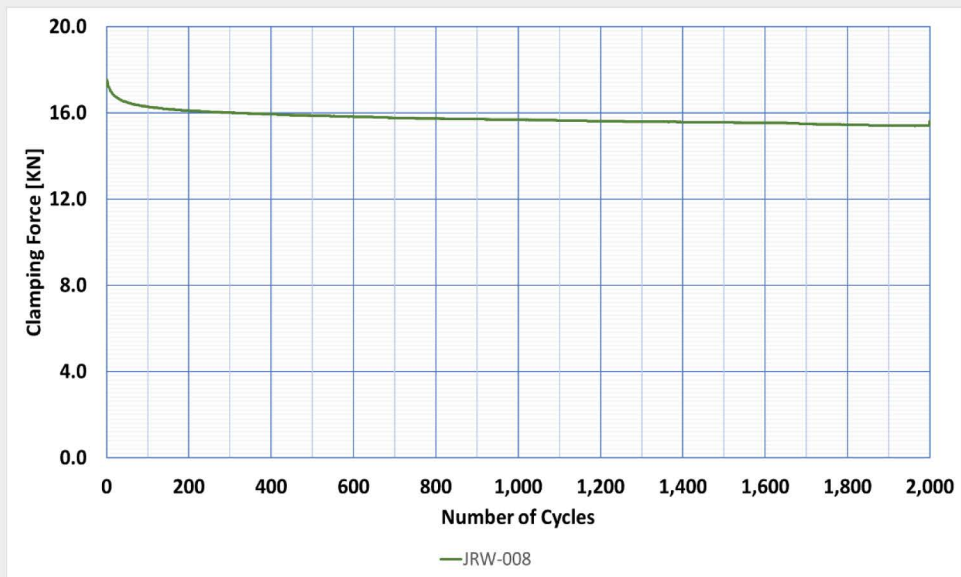
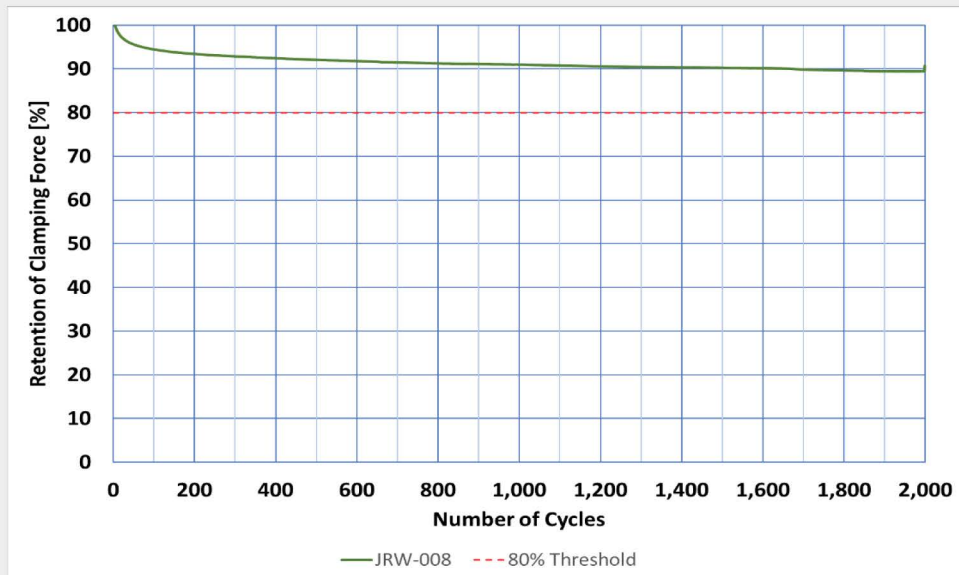

Figure 7 - Vibration Test Results - Clamping Force for 1/2" Fastener with J-Washer (Metric)



6. VIBRATION TEST RESULTS (CONT'D.)

Figure 8 - Vibration Test Results - Retention of Clamping Force [%] for 1/2" Fastener with J-Washer



1-1/2-Inch J-Washer Results

The test result summary for the 1-½ inch J-Washer is shown in Table 3. The 1-½ inch J-Washer maintained an average clamping force of ninety-six percent (96%) of the original load after 2,000 cycles. When monitored over 2,000 cycles the clamping force did not fall below 80% of the original load. The bolt load was monitored throughout the test and is plotted in Figure 9 for imperial and Figure 10 for metric. The relative percent load is plotted in Figure 11. Based on the trajectory of the curves at the end of the test it is unlikely that the bolt load would be loosened even if the test was continued beyond the 2,000 cycles.

Table 3 - Vibration Test Result Summary for 1-1/2" J-Washer

| PARAMETER | VALUE |
|-------------------------------------|------------------------|
| Nominal Bolt Size (imperial/metric) | 1.5" / 38 mm |
| Part Number | JRW-108 |
| Number of Samples Tested | 12 |
| Average Load Original | 78,073 lbf / 347,42 KN |
| Average Load at Cycle 2,000 | 75,106 lbf / 347,22 KN |
| Average Percent Load at Cycle 2,000 | 96% |

6. VIBRATION TEST RESULTS (CONT'D.)

Figure 9 - Vibration Test Results - Clamping Force for 1-1/2" Fastener with J-Washer (Imperial)

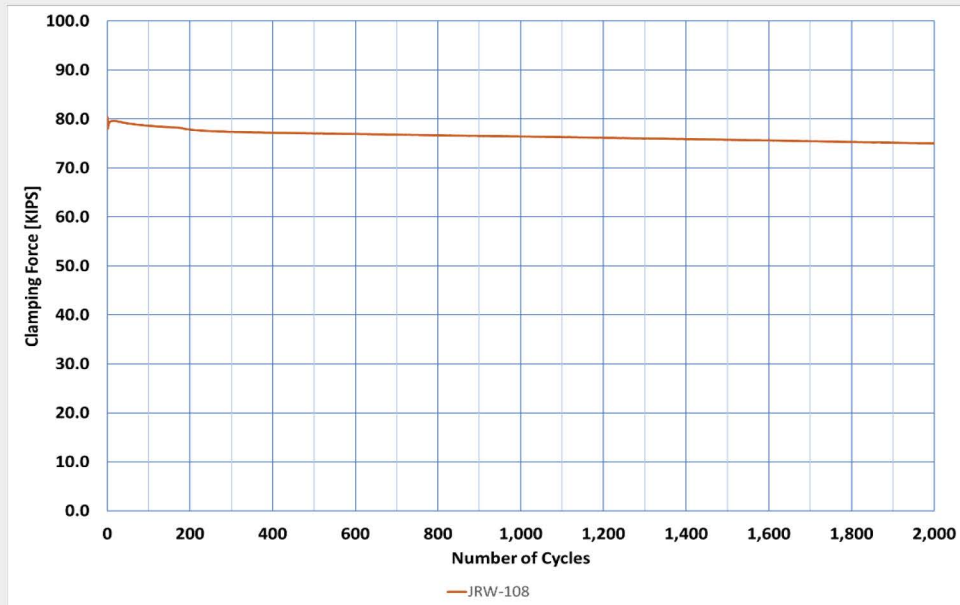
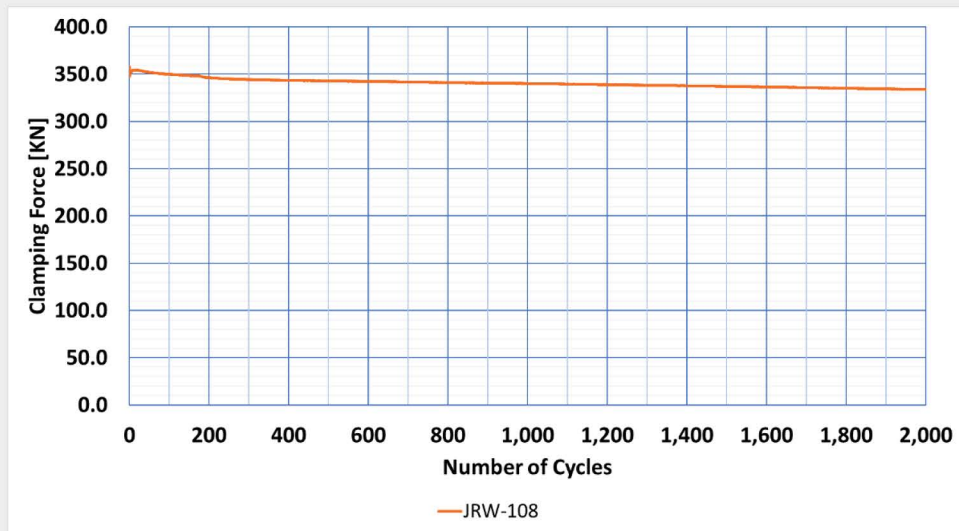
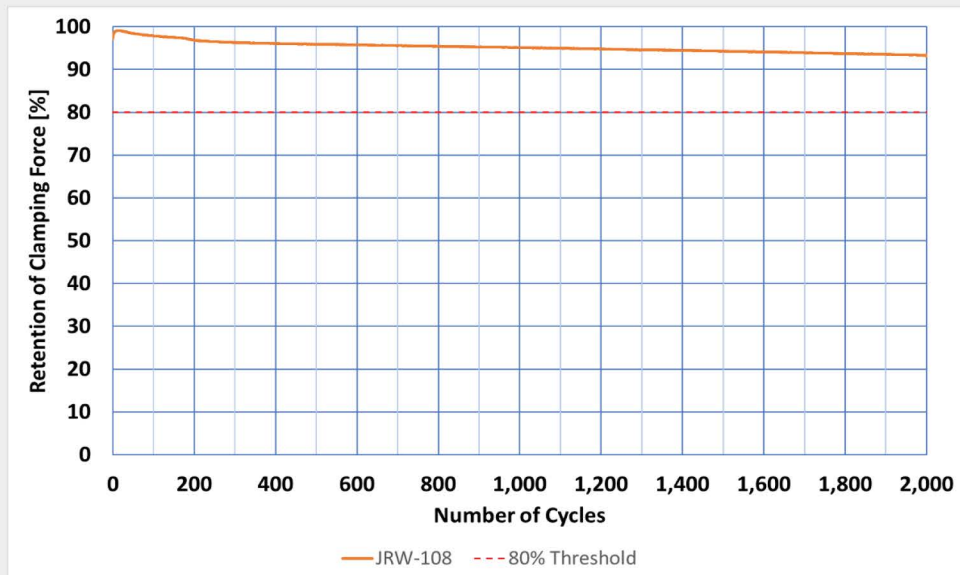

Figure 10 - Vibration Test Results - Clamping Force for 1-1/2" Fastener with J-Washer (Metric)



6. VIBRATION TEST RESULTS (CONT'D.)

Figure 11 – Vibration Test Results - Retention of Clamping Force [%] for 1-1/2" Fastener with J-Washer



1-7/8-Inch J-Washer Results

The test result summary for the 1-7/8 inch J-Washer is shown in Table 4. The 1-7/8 inch J-Washer maintained an average clamping force of ninety-six percent (96%) of the original load after 2,000 cycles. When monitored over 2,000 cycles the clamping force did not fall below 80% of the original load. The bolt load was monitored throughout the test and is plotted in Figure 12 for imperial and Figure 13 for metric. The relative percent load is plotted in Figure 14. Based on the trajectory of the curves at the end of the test it is unlikely that the bolt load would be loosened even if the test was continued beyond the 2,000 cycles.

Table 4 - Vibration Test Result Summary for 1-7/8" J-Washer

| PARAMETER | VALUE |
|-------------------------------------|------------------------|
| Nominal Bolt Size (imperial/metric) | 1.875" / 48 mm |
| Part Number | JRW-114 |
| Number of Samples Tested | 12 |
| Average Load Original | 46,360 lbf / 206,30 KN |
| Average Load at Cycle 2,000 | 50,942 lbf / 226,69 KN |
| Average Percent Load at Cycle 2,000 | 96% |

6. VIBRATION TEST RESULTS (CONT'D.)

Figure 12 - Vibration Test Results - Clamping Force for 1-7/8" Fastener with J-Washer (Imperial)

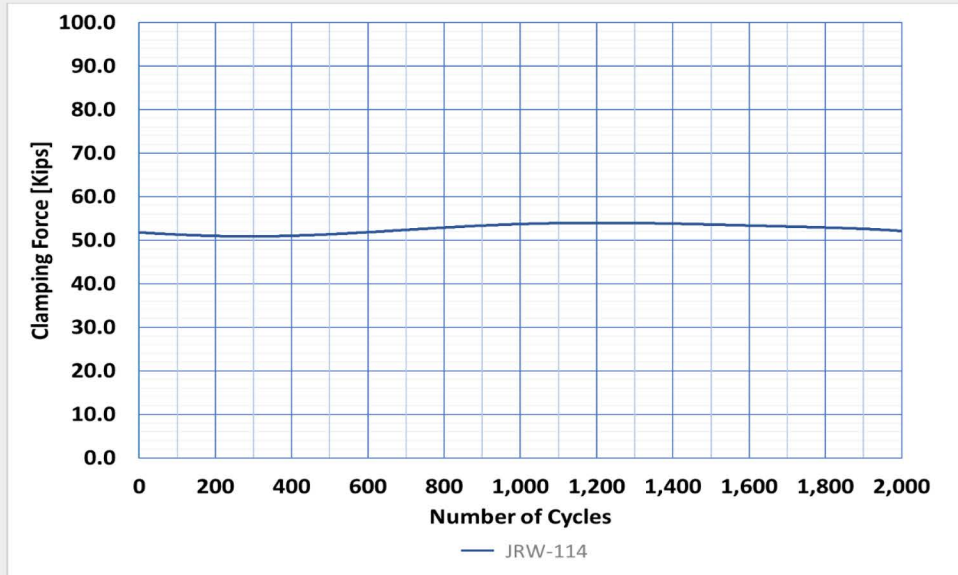
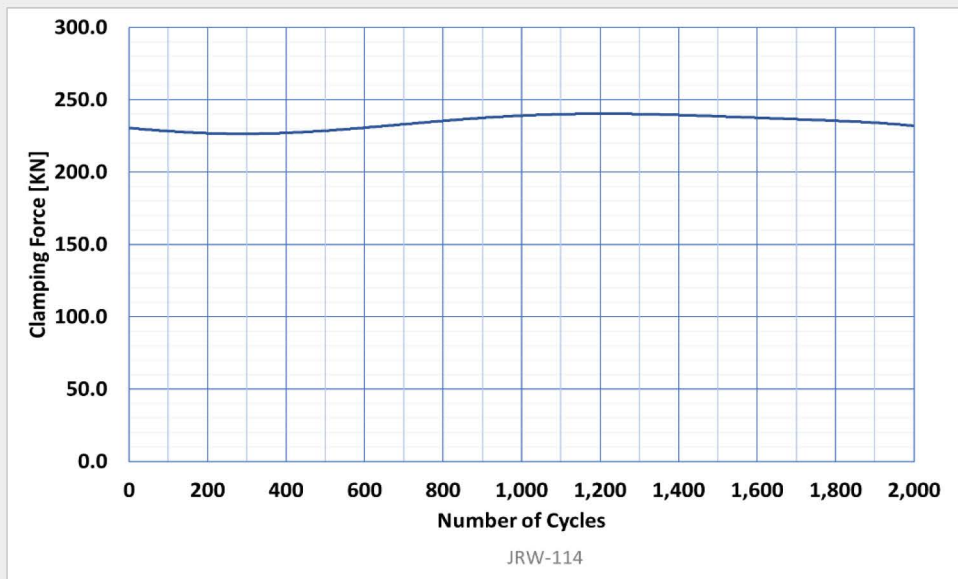
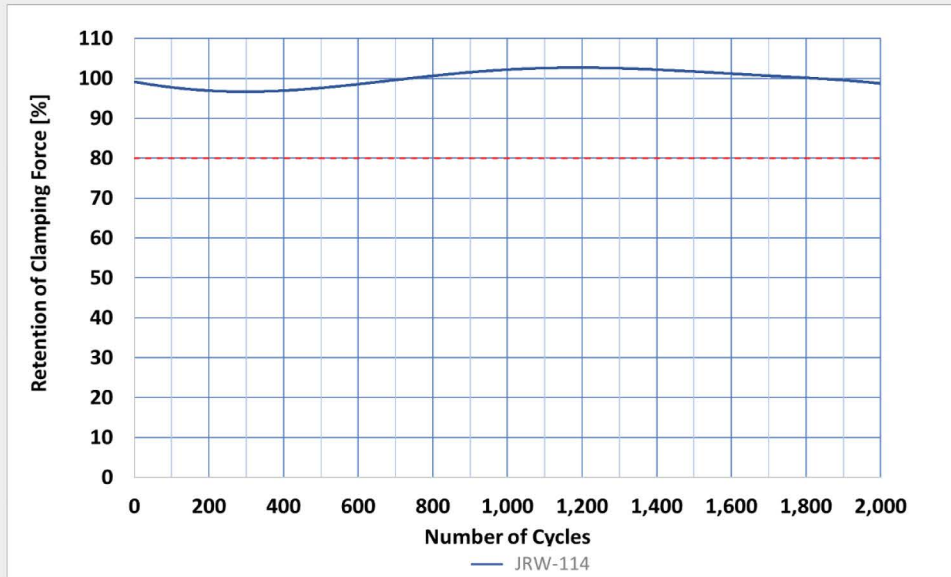

Figure 13 - Vibration Test Results - Clamping Force for 1-7/8" Fastener with J-Washer (Metric)



6. VIBRATION TEST RESULTS (CONT'D.)

Figure 14 - Vibration Test Results - Retention of Clamping Force [%] for 1-7/8" Fastener with J-Washer



7. CONCLUSION

Three J-Washer sizes, ½-inch, 1-½-inch and 1-7/8-inch, were tested by an independent laboratory according to the DIN 25201 vibration test procedure. When monitored over 2,000 cycles (approximately 2 minutes) the clamping force did not fall below 80% of the original load for all three washer sizes. Based on the plot of the clamping force against the number of load cycles, the clamping force curve shows that it is unlikely that either fastener would have failed even if the test continued beyond 2,000 cycles. The retention load plots for all the tested J-Washers (1/2-inch, 1-1/2-inch, 1-7/8-inch) shown that both tested J-Washer can retain the clamping force above the eighty percent (80%) threshold necessary to pass the test per the DIN 25201 standard. The HYTORC J-Washers have demonstrated that they maintain the required clamping force during the testing cycle.

REFERENCES

1. Junker G, New Criteria for Self-Loosening of Fasteners Under Vibration, Transactions of the Society of Automotive Engineers, Vol. 78, 1969, pp. 314-335, New York.
2. DIN 65151: 2002-08 Dynamic testing of the locking characteristics of fasteners under transverse loading conditions (vibration test), Deutsches Institut für Normung c.V., Berlin 2002.
3. DIN 25201-4: 2004-06. Design guide for railway vehicles and their componnets – Bolted Joints – Part 4: Securing of bolting joints, Deutsches Institut für Normung c.V., Berlin 2004.
4. Morten S., DIN 25201 – Important New Standard for Testing Fasteners, Fastener Technology International, 2011, pp. 124-128, retrieved from www.fastenertech.com
5. ASTM F3394/F3394M – 20 Standard Specification for Hardened Steel Backup and Reaction Washers Inch and Metric Dimensions, ASTM International, West Conshohocken 2020

CHANGELOG

UPDATE (6/15/20): Bolt Grade changed to reflect B7 in both columns of the first chart in Section 5.

Legal notice added below table of contents.

UPDATE (9/18/20): Full document rewrite. Footer on last page (below) removed.

UPDATE (11/06/20): Hi-resolution photos of test hardware added. Updated entire document to include both metric and imperial test results. Included new metric clamping force plots for all the tests. Added vibration tests results for 1-7/8 J-Washer size. Corrected the DIN 25201 test designation that was showing as 21205 in the previous edition.

HYTORC WORLD HEADQUARTERS

333 Route 17 North, Mahwah, NJ 07430 • +201-512-9500 • 800-FOR-HYTORC



THE HYTORC UNIVERSE IS MADE UP OF
OVER 1,000 TRAINED BOLTING SPECIALISTS
TO SUPPORT YOUR BOLTING NEEDS IN
OVER 100 COUNTRIES.

Locate your nearest HYTORC representative:

[HYTORC.COM/WORLD](https://www.hytorc.com/world)