



HY-115/HY-230/HY-400 PUMPS

HYTORC's HY-Series of electrically operated hydraulic power packs are fast, reliable, efficient and economical. The HY-Series of 4-stage pumps will outperform any standard pump on the market. These hydraulic pumps operate at a very quiet ~80 dB. All pumps come equipped with an oil cooler, making overheating a thing of the past. Simple controls make for short set-up times. An optional Hour Meter is available to better track run times.

HEAVY DUTY REMOTE



The HY-Series Pump has a heavy duty remote to handle the harshest conditions. The simple 2-button setup makes operations user friendly.

LED LIGHT SYSTEM (HY-115)



The HY-115 Pump is equipped with three-colored (3) LED lights integrated into the electric control box for system monitoring. The LED lights let you know that you are operating within voltage and temperature limits.

FAST 4-STAGE PUMP DESIGN

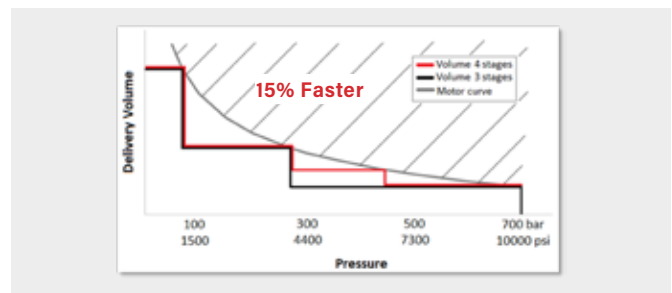

By adding a 4th pressure stage in the 4,000 to 7,000 psi range the HY-115/230 Pump increases the flow of oil to the tool. Allowing the tool to cycle faster and resulting in a 15% time savings over old 3-stage pumps.

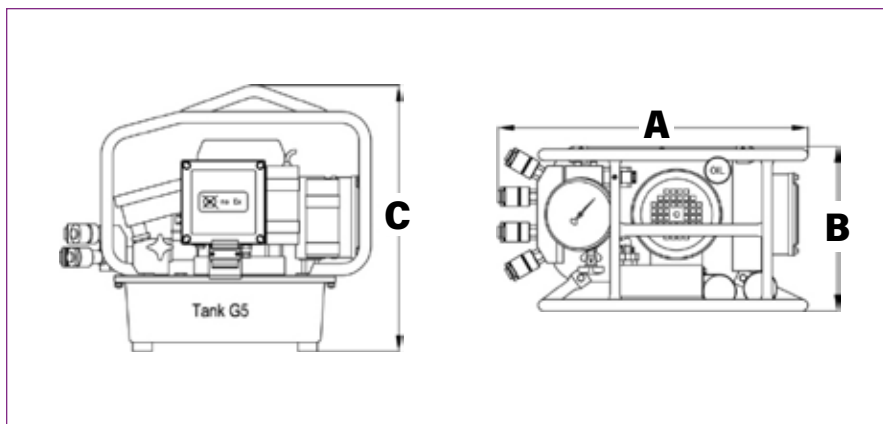

PUMP DIMENSIONS		
	HY-115/230 (G5)	HY-115/230 (G8)
A	18.8 in. 480 mm	18.8 in. 480 mm
B	9.8 in. 250 mm	11.8 in. 280 mm
C	16.1 in. 410 mm	16.7 in. 425 mm

PUMP SPECIFICATIONS AND FEATURES

Power	115v (17 Amp) / 230v (9 Amp) / 400v (6 Amp)		
Gauge	0-10 k PSI (+/-1% Accuracy)		
Reservoir Capacity	1.35 gals. / 5.1 l (2 gals. / 7.6 l tank optional for the HY-115)		
Stages	4		
Weight	57 lbs. / 26 kg (1.35 gallon tank) 60 lbs. / 27 kg (2 gallon tank)		
Hour Meter	Optional		
15' Remote Control	Yes		
Oil Cooler	Yes		
Number of ports	4		
Maximum Oil Flow	HY-115 (60 Hz)	HY-230 (50 Hz)	HY-400 (50 Hz)
1,000 PSI	610 cu.in/min.	549 cu.in/min.	549 cu.in/min.
70 bar	10,0 l/min.	9,0 l/min.	9,0 l/min.
Middle Pressure Oil Flow	HY-115 (60 Hz)	HY-230 (50 Hz)	HY-400 (50 Hz)
3,900 PSI	171 cu.in/min.	147 cu.in/min.	147 cu.in/min.
270 bar	2,8 l/min.	2,4 l/min.	2,4 l/min.
Middle Pressure + Oil Flow	HY-115 (60 Hz)	HY-230 (50 Hz)	HY-400 (50 Hz)
6,300 PSI	110 cu.in/min.	85 cu.in/min.	85 cu.in/min.
440 bar	1,8 l/min.	1,4 l/min.	1,4 l/min.
High Pressure Oil Flow	HY-115 (60 Hz)	HY-230 (50 Hz)	HY-400 (50 Hz)
10,000 PSI	67 cu.in/min.	55 cu.in/min.	55 cu.in/min.
700 bar	1,1 l/min.	0,9 l/min.	0,9 l/min.

The World's Most Trusted Industrial Bolting Systems

HYTORC owns all content, copyrights, trademarks and patents in this document. © 2021 HYTORC. Any unauthorized use or distribution of any material from this document is strictly prohibited.



Headquarters:
333 Route 17 N., Mahwah, NJ 07430
+1-201-512-9500

Email:
info@hytorc.com

Phone:
1-800-FOR-HYTORC

Online:
hytorc.com